

TONiC™ FS T3x3x RTLC20-S linear encoder system Functional Safety installation guide and safety manual

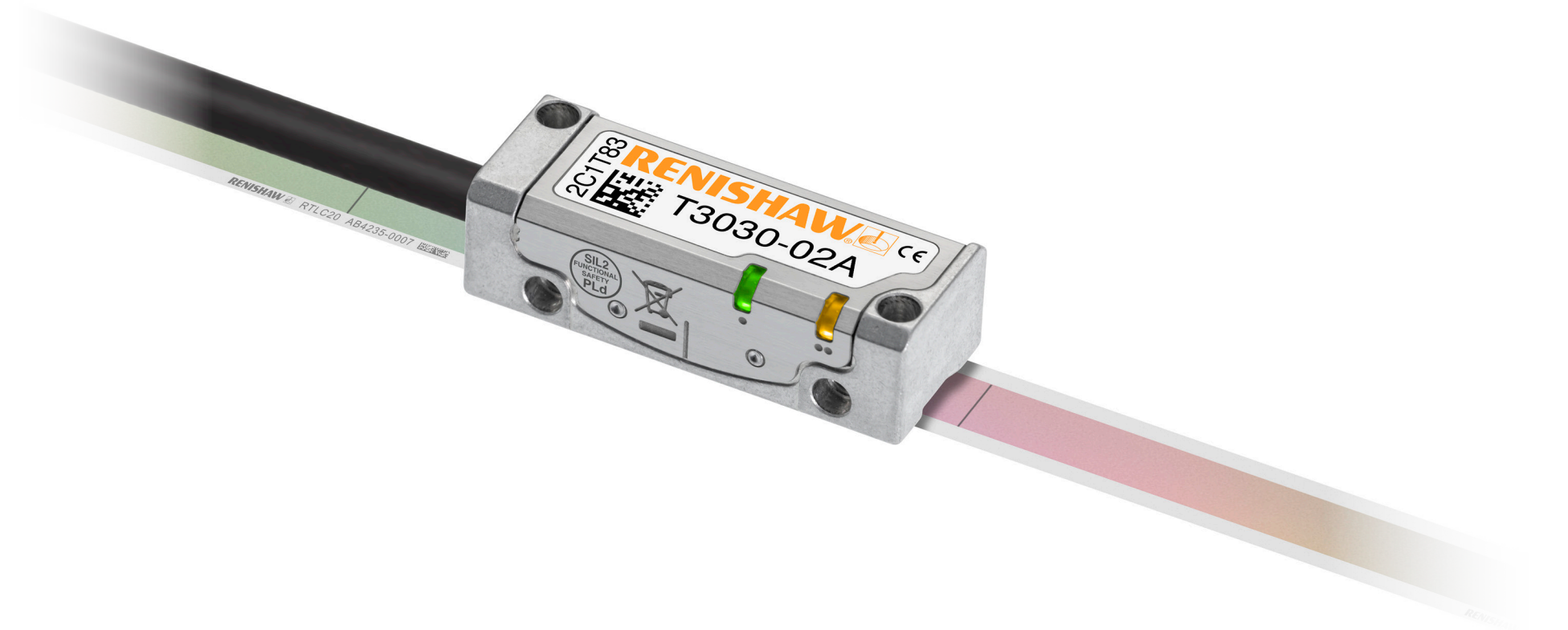

This page is intentionally left blank.

Contents

Legal notices5
Definitions9
Information for use10
Functional Safety data declaration11
Safety sub-functions12
Safety function13
Certification17
Declaration of conformity18
Storage and handling20
TONiC T3x3x readhead installation drawing23
Ti interface drawing24
DOP interface drawing25
RTL20-S scale installation drawing26
Equipment required for installing the RTL20-S scale27
Cutting the RTL20-S scale28
Applying the RTL20-S scale29
Fitting the end covers30
Fitting the datum clamp30
Reference mark selector and limit magnet installation31
TONiC quick-start guide32
Cable connection33
System connection - Ti interface34
System connection - DOP interface36

Readhead mounting and alignment37
Diagnostic LEDs39
System calibration40
Restoring factory defaults41
Switching Automatic Gain Control (AGC) on or off.41
Output signals.42
Speed44
Electrical connections.45
Ti interface output specifications48
DOP interface output specifications50
General specifications52
RTL20-S scale specifications.53
Reference mark54
Limit switches54

Legal notices

Patents

Features of Renishaw's TONiC and RTLC20-S encoder systems are the subjects of the following patents and patent applications:

CN100543424	EP1766334	JP4932706	US7659992	CN100507454
EP1766335	IN281839	JP5386081	US7550710	CN101300463
EP1946048	JP5017275	US7624513	IN317599	CN101310165
EP1957943	US7839296	US8466943		

Terms and conditions and warranty

Unless you and Renishaw have agreed and signed a separate written agreement, the equipment and/or software are sold subject to the Renishaw Standard Terms and Conditions supplied with such equipment and/or software, or available on request from your local Renishaw office.

Renishaw warrants its equipment and software for a limited period (as set out in the Standard Terms and Conditions), provided that they are installed and used exactly as defined in associated Renishaw documentation. You should consult these Standard Terms and Conditions to find out the full details of your warranty.

Equipment and/or software purchased by you from a third-party supplier is subject to separate terms and conditions supplied with such equipment and/or software. You should contact your third-party supplier for details.

Declaration of Conformity

Renishaw plc hereby declares that the TONiC encoder system is in compliance with the essential requirements and other relevant provisions of:

- the applicable EU directives
- the relevant statutory instruments under UK law



The full text of the declaration of conformity is available at www.renishaw.com/productcompliance.

Compliance

Federal Code Of Regulation (CFR) FCC Part 15 – RADIO FREQUENCY DEVICES

47 CFR Section 15.19

This device complies with part 15 of the FCC Rules. Operation is subject to the following two conditions: (1) This device may not cause harmful interference, and (2) this device must accept any interference received, including interference that may cause undesired operation.

47 CFR Section 15.21

The user is cautioned that any changes or modifications not expressly approved by Renishaw plc or authorised representative could void the user's authority to operate the equipment.

47 CFR Section 15.105

This equipment has been tested and found to comply with the limits for a Class A digital device, pursuant to part 15 of the FCC Rules. These limits are designed to provide reasonable protection against harmful interference when the equipment is operated in a commercial environment. This equipment generates, uses, and can radiate radio frequency energy and, if not installed and used in accordance with the instruction manual, may cause harmful interference to radio communications. Operation of this equipment in a residential area is likely to cause harmful interference in which case the user will be required to correct the interference at his own expense.

47 CFR Section 15.27

This unit was tested with shielded cables on the peripheral devices. Shielded cables must be used with the unit to ensure compliance.

Supplier's Declaration of Conformity

47 CFR § 2.1077 Compliance Information

Unique Identifier: TONiC

Responsible Party - U.S. Contact Information

Renishaw Inc.
1001 Wesemann Drive
West Dundee
Illinois
IL 60118
United States
Telephone number: +1 847 286 9953
Email: usa@renishaw.com

ICES-001 — Industrial, Scientific and Medical (ISM) Equipment (Canada)

This ISM device complies with CAN ICES-001.

Cet appareil ISM est conforme à la norme ICES-001 du Canada.

Intended use

The TONiC encoder system is designed to measure position and provide that information to a drive or controller in applications requiring motion control. It must be installed, operated, and maintained as specified in Renishaw documentation and in accordance with the Standard Terms and Conditions of the Warranty and all other relevant legal requirements.

Product compliance

This document is an installation guide and safety manual, which details the actions required for the safe integration of the TONiC Functional Safety (FS) encoder system, as designated by the T3 prefix in the part number, into a functionally safe system; this will be referred to as TONiC FS system in the below document.

The TONiC FS system as defined in this document is suitable for use in a Category 3 performance level d (PLd) application in compliance with ISO 13849 and in a safety integrity level 2 (SIL2) application in compliance with IEC 61508 and IEC 61800-5-2 when installed and operated in accordance with the instructions defined.

Failure to follow the correct use instructions and heed the limitations may result in SIL2 and/or PLd not being achieved and will invalidate the Functional Safety certification.

A copy of the TONiC FS certificate is available from our website at www.renishaw.com/productcompliance.

Further information

Further information relating to the TONiC FS encoder range can be found at www.renishaw.com/safety-encoders and is also available from your local Renishaw representative.

Packaging

The packaging of our products contains the following materials and can be recycled.

Packaging Component	Material	ISO 11469	Recycling Guidance
Outer box	Cardboard	Not applicable	Recyclable
	Polypropylene	PP	Recyclable
Inserts	Low density polyethylene foam	LDPE	Recyclable
	Cardboard	Not applicable	Recyclable
Bags	High density polyethylene bag	HDPE	Recyclable
	Metalised polyethylene	PE	Recyclable

REACH regulation

Information required by Article 33(1) of Regulation (EC) No. 1907/2006 ("REACH") relating to products containing substances of very high concern (SVHCs) is available at www.renishaw.com/REACH.

Disposal of waste electrical and electronic equipment



The use of this symbol on Renishaw products and/or accompanying documentation indicates that the product should not be mixed with general household waste upon disposal. It is the responsibility of the end user to dispose of this product at a designated collection point for waste electrical and electronic equipment (WEEE) to enable reuse or recycling. Correct disposal of this product will help to save valuable resources and prevent potential negative effects on the environment. For more information, please contact your local waste disposal service or Renishaw distributor.

TONiC software notices

Third party licences

Copyright © 2019, Microchip Technology Inc. and its subsidiaries (“Microchip”)

All rights reserved.

This software is developed by Microchip Technology Inc. and its subsidiaries (“Microchip”).

Redistribution and use in source and binary forms, with or without modification, are permitted provided that the following conditions are met:

- Redistributions of source code must retain the above copyright notice, this list of conditions and the following disclaimer.
- Redistributions in binary form must reproduce the above copyright notice, this list of conditions and the following disclaimer in the documentation and/or other materials provided with the distribution.
- Microchip’s name may not be used to endorse or promote products derived from this software without specific prior written permission.

THIS SOFTWARE IS PROVIDED BY MICROCHIP “AS IS” AND ANY EXPRESS OR IMPLIED WARRANTIES, INCLUDING, BUT NOT LIMITED TO, THE IMPLIED WARRANTIES OF MERCHANTABILITY AND FITNESS FOR PURPOSE ARE DISCLAIMED. IN NO EVENT SHALL MICROCHIP BE LIABLE FOR ANY DIRECT, INDIRECT, INCIDENTAL, SPECIAL, EXEMPLARY, OR CONSEQUENTIAL DAMAGES (INCLUDING BUT NOT LIMITED TO PROCUREMENT OF SUBSTITUTE GOODS OR SERVICES; LOSS OF USE, DATA OR PROFITS; OR BUSINESS INTERRUPTION) HOWSOEVER CAUSED AND ON ANY THEORY OF LIABILITY, WHETHER IN CONTRACT, STRICT LIABILITY, OR TORT (INCLUDING NEGLIGENCE OR OTHERWISE) ARISING IN ANY WAY OUT OF THE USE OF THIS SOFTWARE, EVEN IF ADVISED OF THE POSSIBILITY OF SUCH DAMAGE.

US government notice

NOTICE TO UNITED STATES GOVERNMENT CONTRACT AND PRIME CONTRACT CUSTOMERS

This software is commercial computer software that has been developed by Renishaw exclusively at private expense. Notwithstanding any other lease or licence agreement that may pertain to, or accompany the delivery of, this computer software, the rights of the United States Government and/or its prime contractors regarding its use, reproduction and disclosure are as set forth in the terms of the contract or subcontract between Renishaw and the United States Government, civilian federal agency or prime contractor respectively. Please consult the applicable contract or subcontract and the software licence incorporated therein, if applicable, to determine your exact rights regarding use, reproduction and/or disclosure.

Renishaw End User Licence Agreement (EULA)

Renishaw software is licensed in accordance with the Renishaw licence at:

www.renishaw.com/legal/softwareterms.

Definitions

WARNING A hazard with a medium risk of injury if not avoided

ESD handling 	<p>The ESD Susceptibility Symbol consists of a triangle, a reaching hand, and a slash through the reaching hand. The triangle means 'Caution' and the slash through the reaching hand means 'Don't touch'.</p>
Mechanical safe position	<p>The maximum distance the scale might move from its installed position, for example if the fixings work loose.</p>
Evaluation unit	<p>External item of equipment in which the output signal of the encoder is evaluated, e.g. machine controller or safety relay.</p>
System manufacturer	<p>Personnel with responsibility for selecting the encoder and verifying its capability is appropriate for the safety related application.</p>
System installer	<p>Personnel with responsibility for fitting the encoder in the specific application.</p>

Information for use

WARNING Not to be used in environments where there is an explosive atmosphere

WARNING Not to be used by medical devices

The TONiC FS system is designed to be used as part of a safety-related control system as specified by the system manufacturer. It is the responsibility of the system manufacturer to set the evaluation unit to implement the appropriate actions when the TONiC FS system reports an error.

The decision to use this system for the intended purpose is the responsibility of the system manufacturer. The TONiC FS system is certified to the SIL and PL levels as shown in the 'Functional Safety data declaration' table, however the system manufacturer must conduct their own assessment of the full system to determine its safety capability.

Correct use includes:

- Operating the TONiC FS system within the limits defined in this document.
- Installing the system as described in this document.
- Maintaining the system as described in this document.

System components covered by this installation guide:

The TONiC FS system comprises of the following parts:

- TONiC FS readhead
- TONiC Ti0000A00A or DOP interface
- RTLC20-S tape scale
- Accessories

NOTES:

- Only the analogue sine and cosine outputs are functionally safe.
- The UHV cable is for static use only.

If the original termination is altered by the user, or an extension cable is used, then it is the responsibility of the system manufacturer to make sure the system is compliant with IEC 61800-5-2: Annex E second environment – Electromagnetic immunity requirement for safety related systems.

Functional Safety data declaration

Product identification	TONiC™ Functional Safety (FS) encoder system
------------------------	--

IEC 61508 safety data

	TONiC FS readhead	TONiC FS readhead and Ti interface	TONiC FS readhead and DOP interface
Safety Integrity Level	2		
Random Hardware Failures (per hour)	$\lambda_s = 1.77 \times 10^{-7}$ $\lambda_D = 8.41 \times 10^{-8}$ $\lambda_{DD} = 7.57 \times 10^{-8}$ $\lambda_{DU} = 8.41 \times 10^{-9}$	$\lambda_s = 1.77 \times 10^{-7}$ $\lambda_D = 1.38 \times 10^{-7}$ $\lambda_{DD} = 1.25 \times 10^{-7}$ $\lambda_{DU} = 1.38 \times 10^{-8}$	$\lambda_s = 1.77 \times 10^{-7}$ $\lambda_D = 4.14 \times 10^{-7}$ $\lambda_{DD} = 3.73 \times 10^{-7}$ $\lambda_{DU} = 4.14 \times 10^{-7}$
PFDA _{avg}	Not available as this system does not support low demand mode		
PFH (per hour)	$\lambda_{DU} = 8.41 \times 10^{-9}$	$\lambda_{DU} = 1.38 \times 10^{-8}$	$\lambda_{DU} = 4.14 \times 10^{-7}$
Architectural Constraints	Type B HFT = 0 SFF = 96%		
Hardware safety integrity compliance	Route 1H		
Systematic safety integrity compliance	Route 1S		
Systematic capability	SC2		
Demand mode	Continuous		

ISO 13849 safety data

	TONiC FS readhead	TONiC FS readhead and Ti interface	TONiC FS readhead and DOP interface
MTTF _D (years)	1300	800	270
Diagnostic coverage	Medium (90%)		
Category	3		
Performance level	d		
Lifetime/Replacement limits	20 years		

Safety sub-functions

The TONiC Functional Safety (FS) encoder system provides safe position data that supports the following safety sub-functions defined by IEC 61800-5-2:

- Safe stop 1 (SS1) and Safe stop 2 (SS2)
- Safe operating stop (SOS)
- Safe limited acceleration (SLA) $\leq 500 \text{ m/s}^2$
- Safe acceleration range (SAR) $\leq 500 \text{ m/s}^2$
- Safe limited speed (SLS) $\leq 10 \text{ m/s}$
- Safe speed range (SSR) $\leq 10 \text{ m/s}$
- Safely limited position (SLP)
- Safely limited increment (SLI)
- Safe direction (SDI)
- Safe speed monitor (SSM) $\leq 10 \text{ m/s}$

The system must be installed and operated in accordance with the instructions defined by the installation guide. Failure to follow the correct use instructions and failure to heed the limitations may result in PLd and / or SIL2 not being achieved and will invalidate the functional safety certification.

Safety function

The TONiC FS encoder system provides 1 Vpp (nominal) sine and cosine outputs, where the sine and cosine outputs are 90° phase shifted, in order for the evaluation unit to perform incremental counting and thereby confirm machine position is within safe limits.

The following restrictions apply to this claim:

- The system installer must perform a verified commissioning test during installation.
- The system repairer must perform a verified commissioning test following replacement of a system part.
- When installed correctly, the TONiC FS system shall have mechanical safe position not exceeding ± 1 mm

NOTE: Thermal expansion effects of the scale and readhead mounting tolerances are excluded from the mechanical safe position.

- The TONiC FS system includes no self-diagnostic function.

NOTE: Faults are detected only by the evaluation unit monitoring. When errors are detected it is the responsibility of the system manufacturer to place the system into a safe state.

Fault exclusions

The following actions will invalidate the Functional Safety certification of the TONiC FS system:

- Faults caused by cutting and reconnecting the readhead cable or extending the readhead cable.
- Incorrect installation of the readhead.
- Incorrect installation of the RTALC20-S scale.
- Failure to follow the instructions contained within this installation manual.
- Dismantling of the TONiC readhead, Ti0000A00A interface or the DOP interface.
- Operating the system outside of the limits specified within this installation manual.

Failure modes

Failure modes are detected by evaluation unit monitoring. See '[Functional Safety data declaration](#)' on page 11 for a summary of the FMEDA.

NOTE: For the purposes of the FMEDA calculation the following conditions have been assumed:

Method	SN29500-2005-1
Environment	Ground mobile
Temperature	85 °C

Installation

For the safety function to be valid the instructions detailed in this installation guide must be followed. The information relating to all scale types and mounting options is listed. The builder/installer/maintainer/repairer must apply the instructions for the product being installed as defined by this installation guide.

The following general conditions must be observed during installation:

- Observe ESD handling precautions when handling the cable connectors.
- Cleaning mating surfaces before mounting the scale.

Commissioning test

The following checks **MUST** be performed following installation and commissioning of the TONiC FS encoder system for the first time, and also following repair of the system (replacement systems parts):

Axis movement check

Move the axis over its full travel to verify the following:

- Position output is correct within a tolerance of $\pm 10\%$.
- Direction of movement is correct.
- The signal amplitude for both sine and cosine signals falls within the limits defined in 'Evaluation unit monitoring'.

NOTE: Should the working temperature of the readhead need to be measured attach a suitable sensor directly to the aluminium readhead housing. Do not attach to the label that shows the product details. Do not drill into the housing as this may compromise the sealing or technical function. Route the sensor cable away from moving parts and along the same path as the readhead cable.

Evaluation unit monitoring

To achieve full system integrity the evaluation unit must continuously monitor the analogue outputs and, in the case of fault detection, place the system into a safe state within the process safety time.

Signal amplitude check	Nominal signal amplitude value is 1 V, indicating full signal strength where $\sqrt{(\text{sine}^2 + \text{cosine}^2)} = 1 \text{ V}$. A fault condition must be asserted if the analogue output is $\leq 0.7 \text{ V}$ and $\geq 1.35 \text{ V}$.
Sine/cosine cross check	Sine and cosine signals must be evaluated separately and the results compared. A fault condition must be asserted if the phase shift is incorrect with reference to the safe position limit for the system, see ' Ti interface output specifications ' on page 48 or ' DOP interface output specifications ' on page 50.
Following error check	Following error is defined as the difference between the expected position and position feedback. A fault condition must be asserted if the following error exceeds the safe position limit for the system.

NOTES:

- The evaluation unit must achieve medium diagnostic coverage ($\geq 90\%$) according to ISO 13849.
 - Improper setting of the switching thresholds and hysteresis in signal evaluation can result in incorrect determination of direction of movement, position or speed.
 - A persistent fault condition may indicate a hardware failure of the TONiC FS system or an installation problem.
-

Storage and handling

DO ensure that protection is provided for the scale, readhead and interfaces when transporting a machine with that equipment already installed.

DO store scale in a cool dry place out of direct sunlight and in its original packaging prior to installation.

DO allow scale to acclimatize to installation environment prior to installation.

DO store at < 95% RH

DO operate at < 80% RH

DO install between 15 °C and 25 °C

DO store between -20 °C and +70 °C

DO operate between 0 °C and +70 °C

Maintenance and cleaning

In order to retain full Functional Safety compliance, this encoder system needs to be maintained appropriately. The maintenance check intervals will be defined by the machine builder/installer according to their risk assessment. There are no user serviceable parts within the readhead or interface. The lid of the readhead must not be removed.

The following checks should be carried out:

- Check the readhead to bracket screws are correctly tightened.
- Check for worn or damaged cable connecting the readhead to the interface.
- Check that the scale has not been damaged or contaminated. If required, clean the system using approved solvents (see 'Storage and handling' on page 20).

NOTE: Do not attempt to move the RTALC20-S scale as this will damage the adhesive bond.

When cleaning the system:

DO use Renishaw (A-9523-4040) alcohol wetted scale wipes to clean the readhead optics and scale, available from your local Renishaw representative.

Or use a clean, dry, lint-free cloth.

Or use only the following solvents sparingly with a wetted lint-free cloth:

- Propan-2-ol (iso-propyl alcohol) $\text{CH}_3\text{CHOHCH}_3$
- n-Heptane $\text{CH}_3(\text{CH}_2)_5\text{CH}_3$

DO NOT use the following aggressive solvents to clean the TONiC FS readhead or the RTALC20-S scale:

- Acetone CH_3COCH_3
- Chlorinated solvents
- Methylated spirits

Repair

Repair is by replacement of system parts only. The replacement parts must have the same part number as the parts being replaced. The new system must be installed and commissioned in accordance with the 'Commissioning test' on page 14. It is advisable that, in the event of failure, the affected parts should be returned to Renishaw for further analysis. Using damaged parts invalidates the Functional Safety certification.

Proof testing

It is the responsibility of the system manufacturer to define any proof testing of the system. Due to the diagnostic coverage (DC) and safe failure fraction (SFF) required to achieve SIL2, the encoder can only support continuous demand use.

Certification

TONiC FS encoder system
Functional Safety Certificate No. FSC001



Under the terms of CSA SIRA Functional Safety Certificate SIRA CASS00023/02, for the management and self-certification of functional safety activities up to SIL3/PLd:

Renishaw plc declares that the products shown by this installation guide meet the requirements of:

IEC 61508-1:2010, IEC 61508-2:2010 and IEC 61508-3:2010

IEC 61800-5-2:2016

ISO 13849-1:2015 and ISO 13849-2:2012

when used as an element/subsystem in safety related systems performing safety functions requiring up to and including:

SIL2 with HFT = 0 (1oo1)

Category 3, PLd

Declaration of conformity

Summary of the EU declaration of conformity EUD2021-00817

This declaration of conformity is issued under the sole responsibility of the manufacturer, Renishaw plc.

The object of the declaration is identified below: -

Product name:	TONiC Functional Safety (FS) encoder system
Description:	Revision of TONiC, to comply with the requirements of Functional Safety.

Part number:	Valid from:	Description:
T3xxx*	2AHF37	TONiC FS linear readhead

The object of the declaration described above is in conformity with all relevant EU harmonisation legislation and fulfils all the relevant provisions with EU directives: -

2006/42/EC	Machinery Directive
2014/30/EU	Electromagnetic Compatibility (EMC)
2011/65/EU	On the restriction of the use of certain hazardous substances in electrical and electronic equipment - RoHS

and complies with the following technical standards: -

EN ISO 12100:2010	Safety of machinery - General principles for design - Risk assessment and risk reduction (ISO 12100:2010)
EN ISO 13849-1:2015	Safety of machinery - Safety-related parts of control systems - Part 1: General principles for design (ISO 13849-1:2015)
EN ISO 13849-2:2012	Safety of machinery - Safety-related parts of control systems - Part 2: Validation (ISO 13849-2:2012)
EN 61326-1:2013	Electrical equipment for measurement, control and laboratory use - EMC requirements - Part 1: General requirements
EN 62471:2008	Photobiological safety of lamps and lamp systems
EN IEC 63000:2018	Technical documentation for the assessment of electrical and electronic products with respect to the restriction of hazardous substances

For the full declaration of conformity EUD2021-00817 see www.renishaw.com/productcompliance.

EU based person authorised to compile the technical file: - Renishaw (Ireland) DAC, Swords Business Park, Swords, Co. Dublin, K67 FX67, Ireland.

Summary of the UK declaration of conformity UKD2021-00817

This declaration of conformity is issued under the sole responsibility of the manufacturer, Renishaw plc.

The object of the declaration is identified below: -

Product name:	TONiC Functional Safety (FS) encoder system
Description:	Revision of TONiC, to comply with the requirements of Functional Safety.

Part number:	Valid from:	Description:
T3xxx*	2AHF37	TONiC FS linear readhead

The object of the declaration described above is in conformity with all relevant UK Statutory Instruments (and their amendments): -

S.I. 2008 No. 1597	Supply of Machinery (Safety) Regulations 2008
S.I. 2016 No. 1091	Electromagnetic Compatibility Regulations 2016
S.I. 2012 No. 3032	The Restriction of the Use of Certain Hazardous Substances in Electrical and Electronic Equipment Regulations 2012 - RoHS

and complies with the following technical standards: -

EN ISO 12100:2010	Safety of machinery - General principles for design - Risk assessment and risk reduction (ISO 12100:2010)
EN ISO 13849-1:2015	Safety of machinery - Safety-related parts of control systems - Part 1: General principles for design (ISO 13849-1:2015)
EN ISO 13849-2:2012	Safety of machinery - Safety-related parts of control systems - Part 2: Validation (ISO 13849-2:2012)
EN 61326-1:2013	Electrical equipment for measurement, control and laboratory use - EMC requirements - Part 1: General requirements
EN 62471:2008	Photobiological safety of lamps and lamp systems
EN IEC 63000:2018	Technical documentation for the assessment of electrical and electronic products with respect to the restriction of hazardous substances

For the full declaration of conformity UKD2021-00817 see www.renishaw.com/productcompliance.

Storage and handling

TONiC non-contact optical encoder systems provide good immunity against contaminants such as dust, fingerprints and light oils. However, in harsh environments such as machine tool applications, protection should be provided to prevent ingress of coolant or oil.

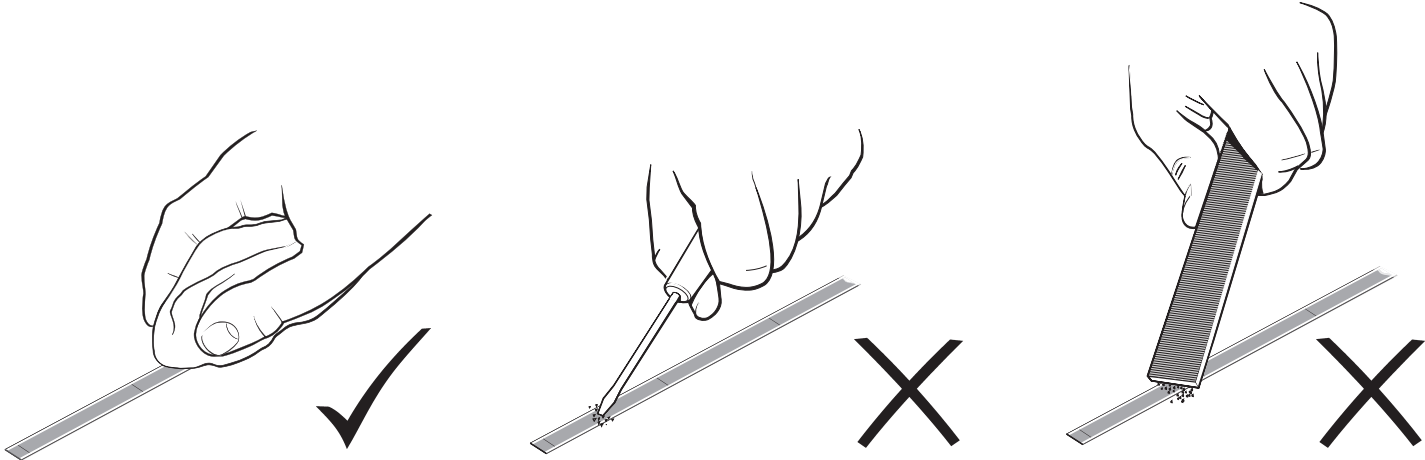

Minimum bend radius

RTLC20-S - 150 mm

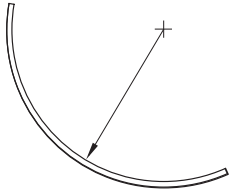

NOTE: Ensure self-adhesive tape is on the outside of bend.

System

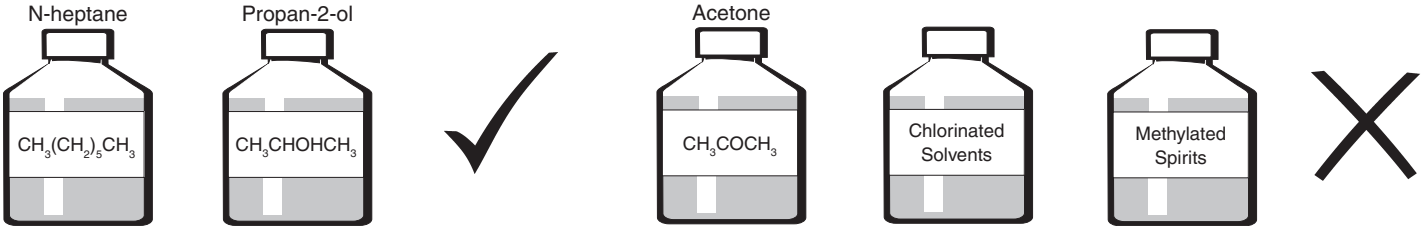

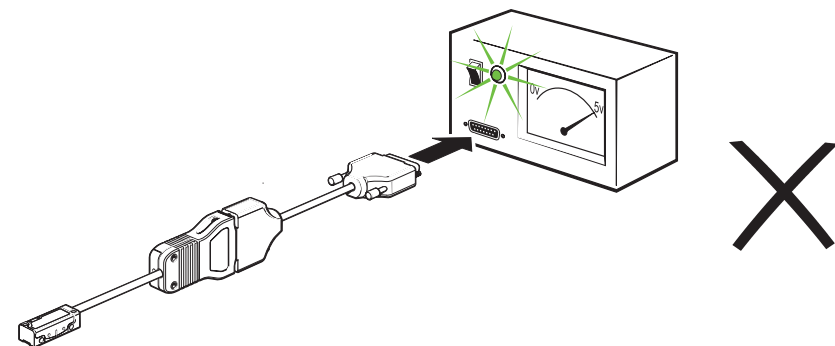
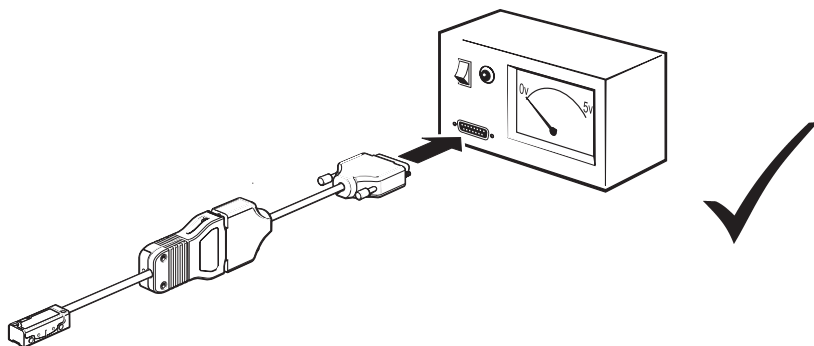
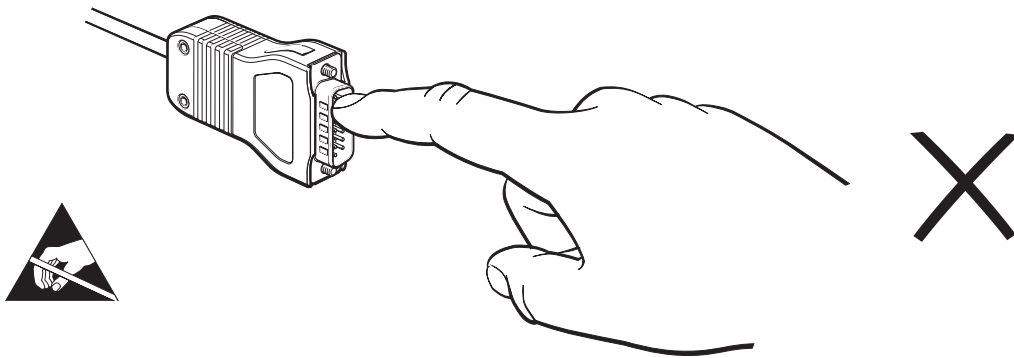
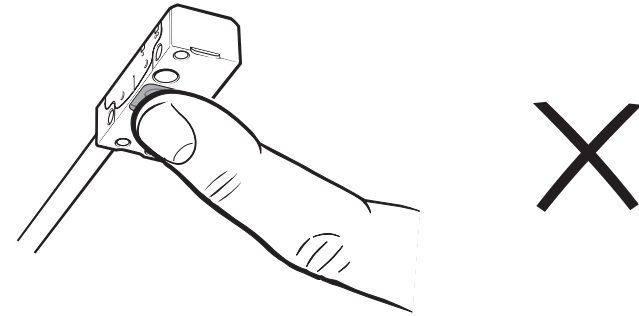
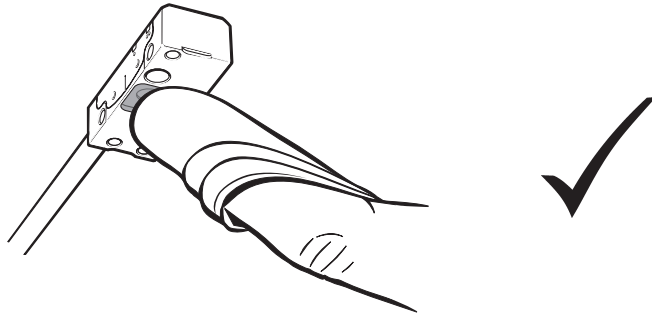

Temperature

Storage	
System	-20 °C to +70 °C

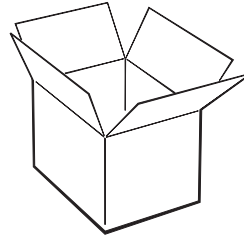

Operating	
System	0 °C to +70 °C

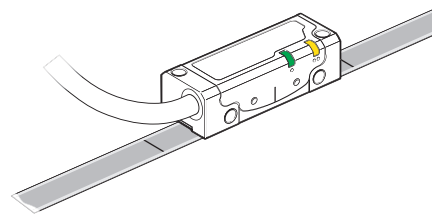

Humidity

95% relative humidity (non-condensing) to IEC 60068-2-78

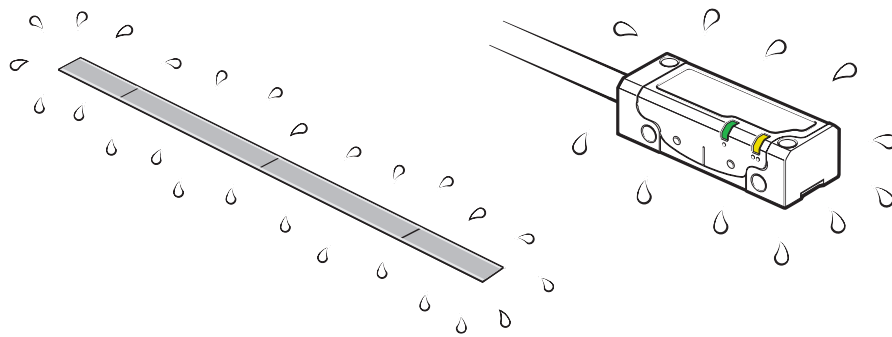

TONiC T3x3x readhead installation drawing

Dimensions and tolerances in mm

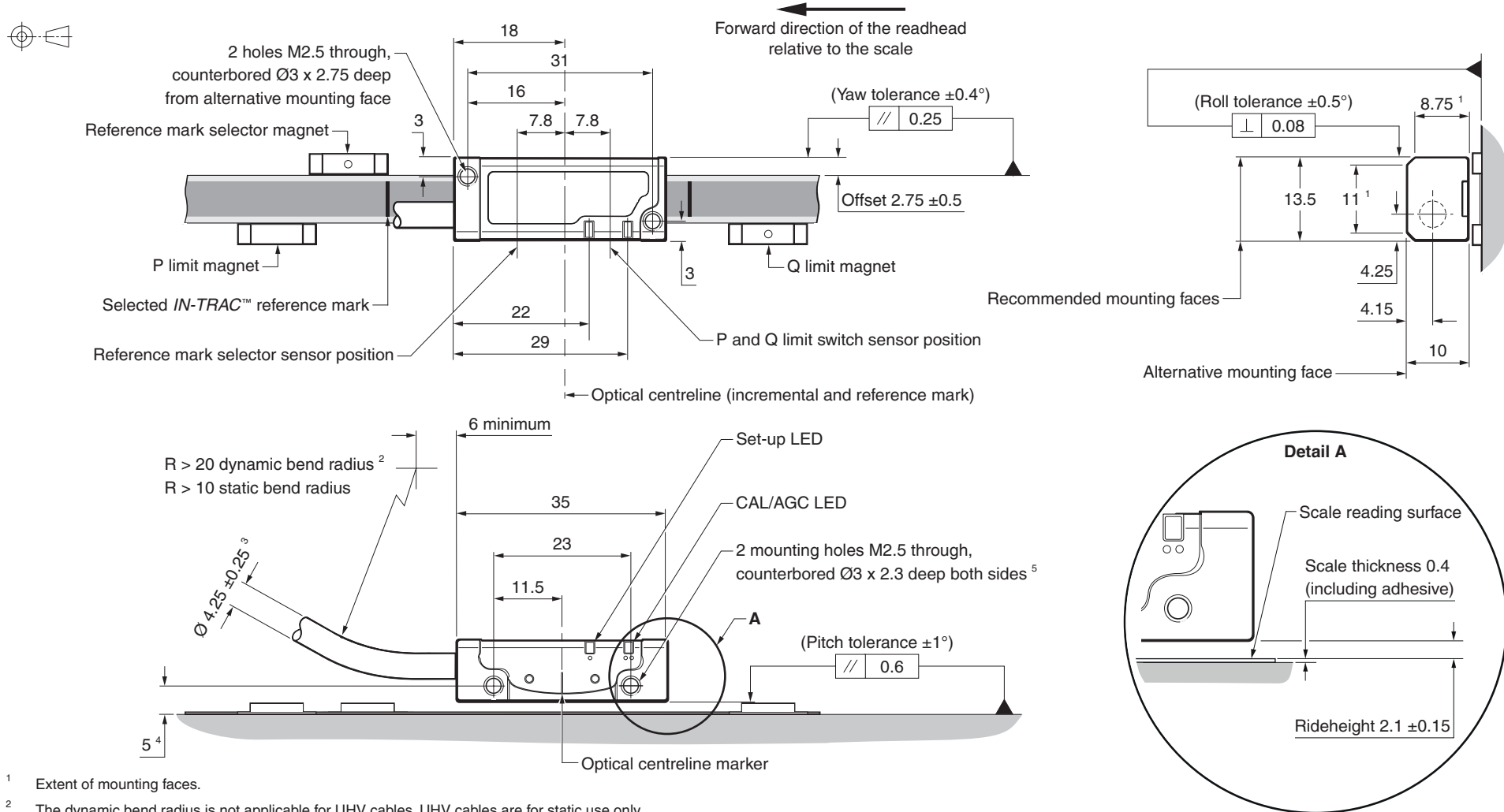

- 1 Extent of mounting faces.
- 2 The dynamic bend radius is not applicable for UHV cables. UHV cables are for static use only.
- 3 The UHV cable diameter is approximately 3 mm.
- 4 Dimension from substrate.
- 5 The recommended thread engagement is 5 mm minimum (7.5 mm including counterbore) and the recommended tightening torque is 0.25 Nm to 0.4 Nm.

Ti interface drawing

Dimensions and tolerances in mm

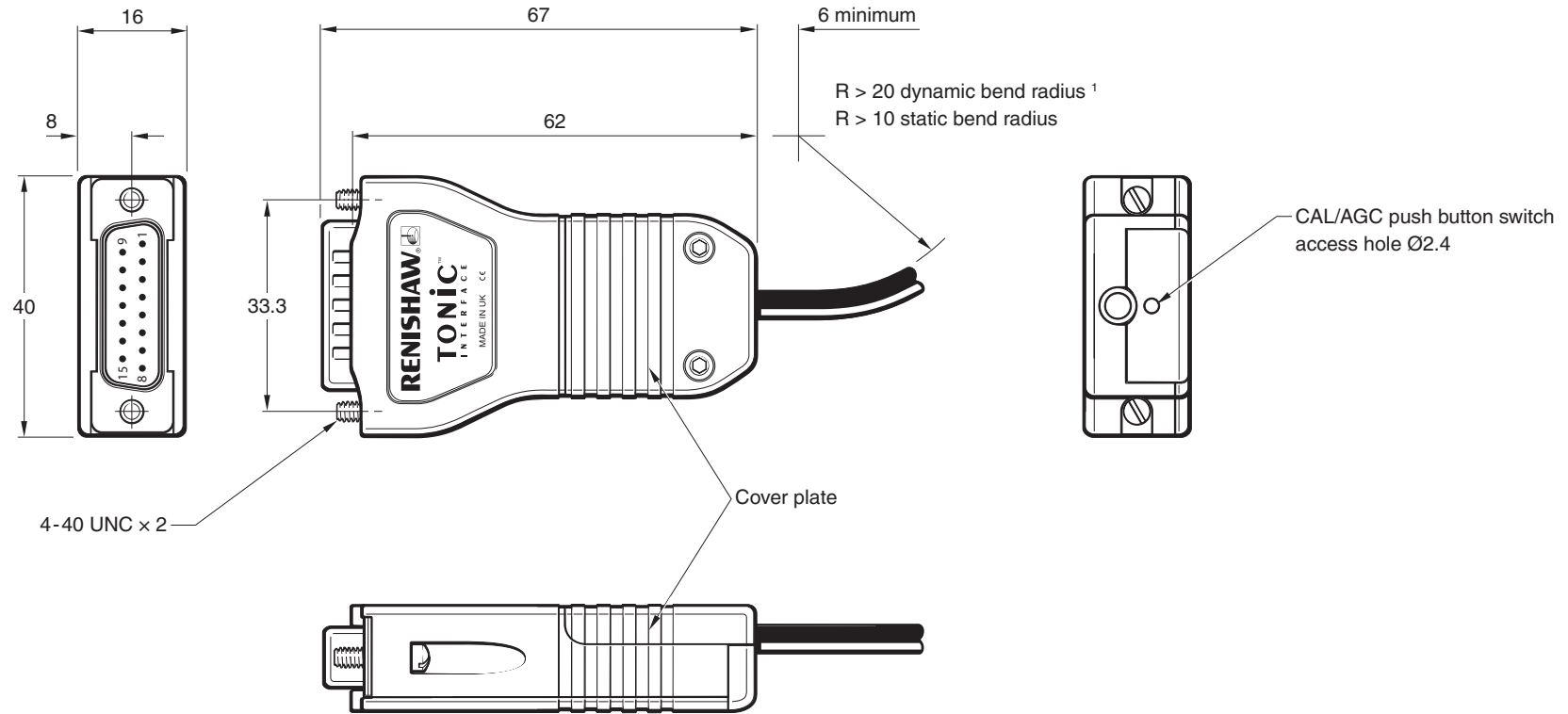

CAL button operation

Function	Operation
Calibration (CAL) routine enable/disable	Push and release (< 3 seconds)
Automatic Gain Control (AGC) enable/disable	Push and release (> 3 seconds)
Restore factory defaults	Push and hold during power 'Off/On' cycle

¹ The dynamic bend radius is not applicable for UHV cables. UHV cables are for static use only.

DOP interface drawing

Dimensions and tolerances in mm

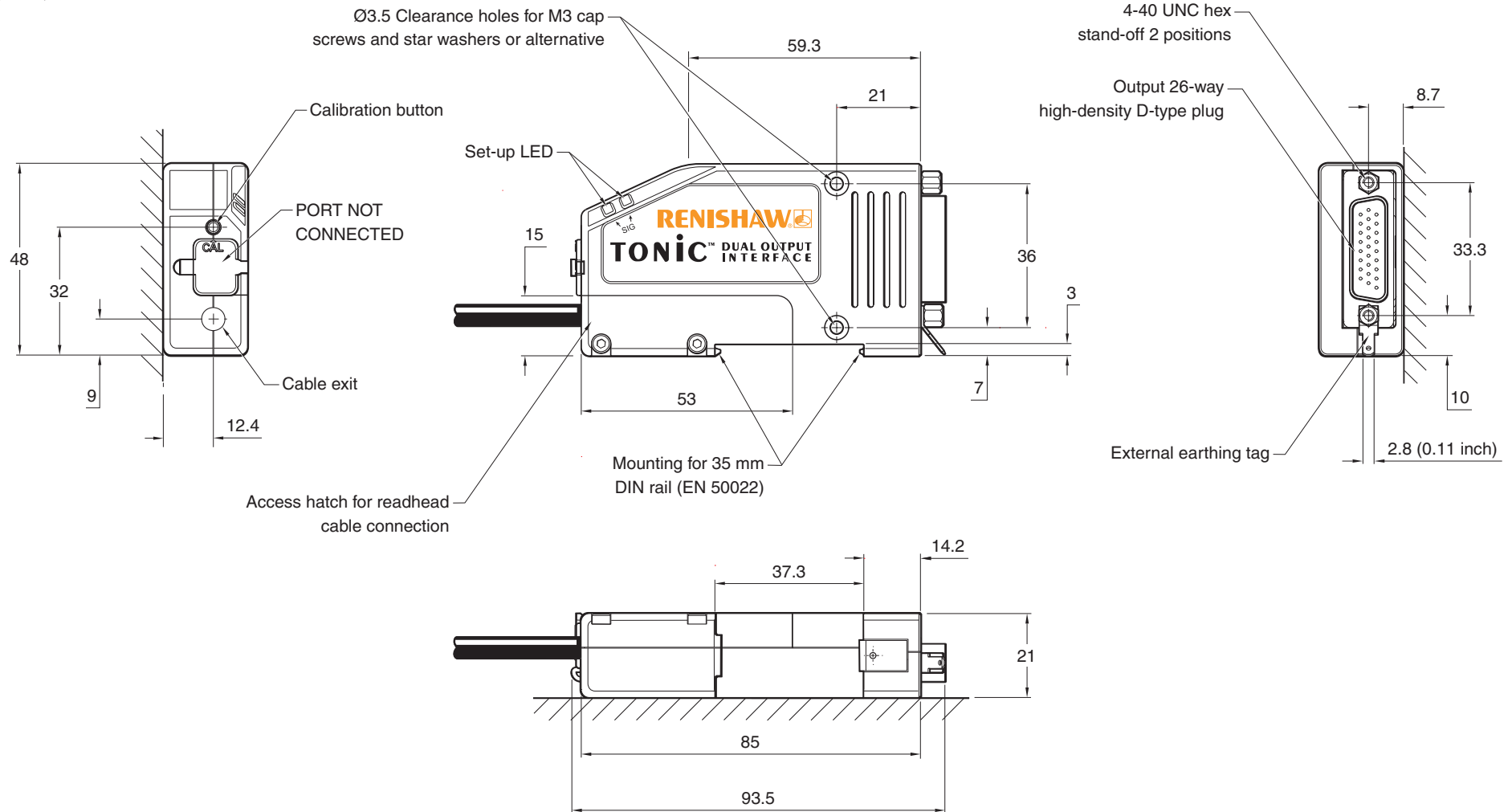

RTL20-S scale installation drawing

Dimensions and tolerances in mm

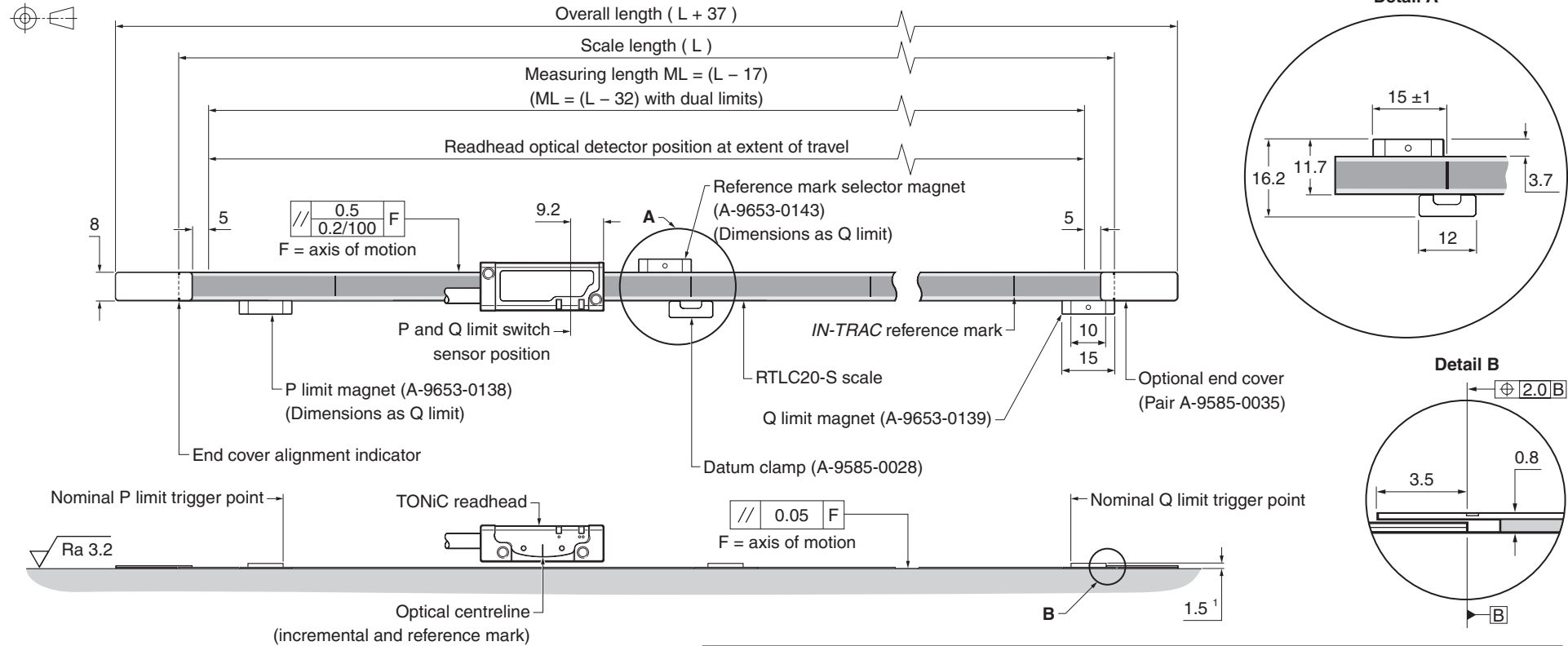

NOTES:

- The reference mark selector and limit actuator locations are correct for the readhead orientation shown.
- External magnetic fields greater than 6 mT, in the vicinity of the readhead, may cause false activation of the limit and reference sensors.

¹ Dimension from substrate.

² Supplied with 2 × M2 × 4 screws.

Optional bolted reference mark selector and limit magnets

Bolted magnet type	Part number
Reference mark selector	A-9653-0290
Q limit	A-9653-0291
P limit	A-9653-0292

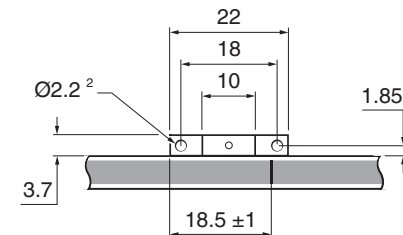

Equipment required for installing the RTALC20-S scale

Required parts:

- Appropriate length of RTALC20-S scale (see '[RTALC20-S scale installation drawing](#)' on page 26)
- Side mount scale applicator (A-9589-0115) or top mount scale applicator (A-9589-0094)
- Datum clamp (A-9585-0028)
- Loctite® 435™ (P-AD03-0012)
- Appropriate cleaning solvents (see '[Storage and handling](#)' on page 20)
- 2 × M2.5 screws
- Green shim (supplied with TONiC readhead)
- Lint-free cloth

Optional parts:

- Renishaw scale wipes (A-9523-4040)
- End cover kit (A-9585-0035)
- Reference mark selector magnet ¹ (A-9653-0143)
- Q limit magnet (A-9653-0139)
- P limit magnet (A-9653-0138)
- Magnet applicator tool (A-9653-0201)
- Loctite 435 dispensing tip (P-TL50-0209)
- Guillotine (A-9589-0071) or shears (A-9589-0133) for cutting RTALC20-S to length required

¹ The reference mark selector magnet is only required for 'Customer selectable reference mark' readheads.

Cutting the RTALC20-S scale

If required cut the RTALC20-S scale to length using a guillotine or shears.

Using the guillotine

The guillotine should be held securely in place, using a suitable vice or clamping method.

Once secured, feed the RTALC20-S scale through the guillotine as shown, and place the guillotine press block down onto the scale.

NOTE: Ensure the block is in the correct orientation (as shown below).

Guillotine press block orientation when cutting RTALC20-S scale

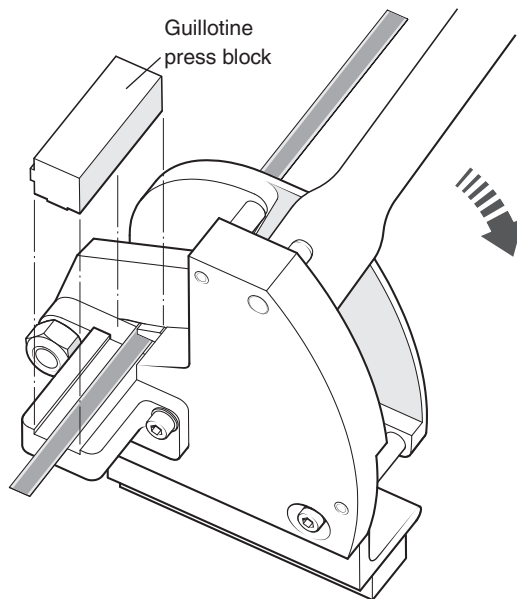

Whilst holding the block in place, in a smooth motion, pull down the lever to cut through the scale.

Using the shears

Feed the RTALC20-S scale through the centre aperture on the shears (as shown).

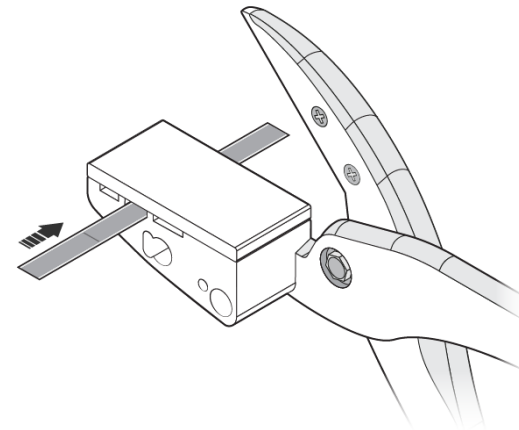

Hold the scale in place and close the shears in a smooth motion to cut through the scale.

Applying the RTALC20-S scale

There are two versions of scale applicator for use with the RTALC20-S scale; side mount and top mount. The side mount version is shown below, but the application method is the same for both versions of the scale applicator.

1. Allow the scale to acclimatise to the installation environment prior to installation.
2. Mark out the start position for the scale on the axis substrate ensuring that there is enough room for the end covers if required (see '[RTALC20-S scale installation drawing](#)' on page 26).
3. Thoroughly clean and degrease the substrate using the recommended solvents (see '[Storage and handling](#)' on page 20). Allow the substrate to dry before applying the scale.
4. Mount the appropriate scale applicator to the readhead mounting bracket. Place the green shim supplied with the readhead between the applicator and the substrate to set the nominal height.

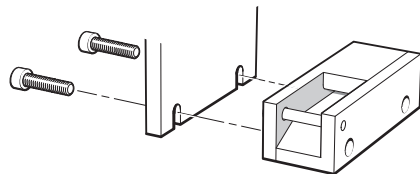

NOTE: The scale applicator can be mounted either way round to enable the easiest orientation for the scale installation.

5. Move the axis to the start of travel leaving enough room for the scale to be inserted through the applicator, as shown below.
6. Begin to remove the backing paper from the scale and insert the scale into the applicator up to the start position. Ensure the backing tape is routed under the splitter screw.

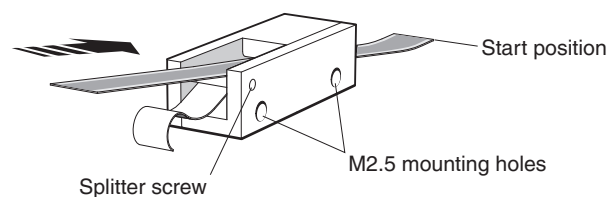

7. Apply firm finger pressure via a clean, dry, lint-free cloth to ensure the scale end adheres well to the substrate.
8. Slowly and smoothly move the applicator through the entire axis of travel. Ensure the backing paper is pulled manually from the scale and does not catch under the applicator.

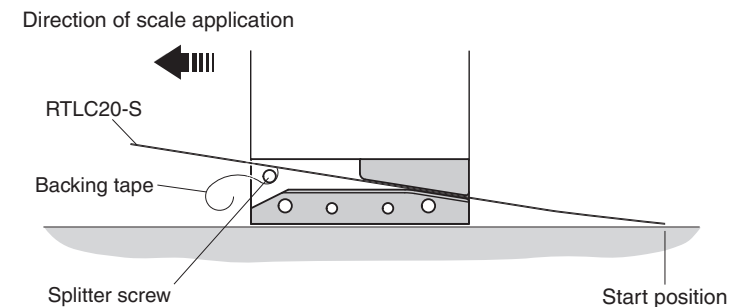

9. During installation ensure the scale adheres to the substrate using light finger pressure.
10. Remove the applicator and, if necessary, adhere the remaining scale manually.
11. Apply firm finger pressure via a clean, dry, lint-free cloth along the length of the scale after application to ensure complete adhesion.
12. Clean the scale using Renishaw scale cleaning wipes or a clean, dry, lint-free cloth.
13. Fit the optional end covers (see '[Fitting the end covers](#)' on page 30).
14. Allow 24 hours for complete adhesion of the scale before fitting the datum clamp (see '[Fitting the datum clamp](#)' on page 30).

Fitting the end covers

The end cover kit is designed to be used with the RTALC20-S scale to provide protection for exposed scale ends.

NOTE: The end covers can be fitted before or after readhead installation.

1. Remove the backing tape from the adhesive tape on the back of the end cover.

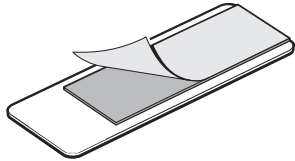

2. Align markers on the edges of the end cover with the end of the scale and place the end cover over the scale.

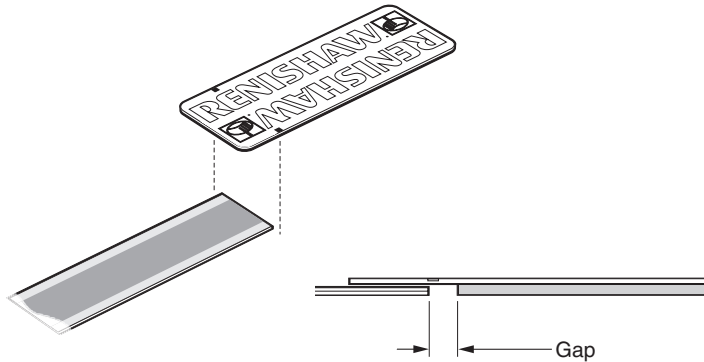

NOTE: There will be a gap between the end of the scale and the adhesive tape on the end cover.

Fitting the datum clamp

IMPORTANT: Allow 24 hours after scale application before fitting the datum clamp.

The datum clamp fixes the RTALC20-S scale rigidly to the substrate at the location chosen.

CAUTION: The metrology of the system may be compromised if the datum clamp is not used.

The datum clamp does not need to be fitted adjacent to a reference mark. It can be positioned anywhere along the axis depending upon the customers' requirements.

1. Remove the backing paper from the datum clamp.
2. Place the datum clamp with cut-out against the scale at the chosen location.

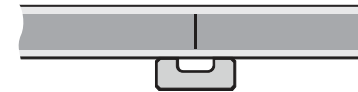

3. Place a small amount of adhesive (Loctite® 435™) in the cut-out on the datum clamp, ensuring none of the adhesive wicks onto the scale surface. Dispensing tips for the adhesive are available.

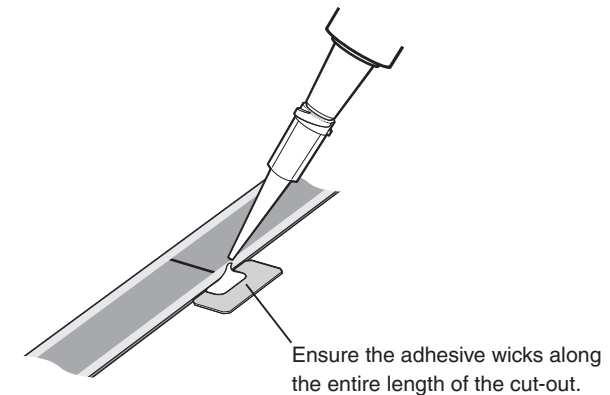

Reference mark selector and limit magnet installation

IMPORTANT: Allow 24 hours after the scale application before fitting the magnets.

For accuracy and ease of positioning of the reference mark selector and limit magnets, the applicator tool should be used. The magnet should be attached to the applicator tool as shown. Limit magnets can be positioned at any user defined location along the scale, but the reference mark selector magnet should be positioned adjacent to the selected *IN-TRAC* reference mark as shown.

As the TONiC FS readhead passes the reference mark selector magnet or limit switch magnet, a force of up to 0.2 N is generated between the magnet and the concentrators on the readhead. The design of the bracket should be sufficiently stiff so that it is able to tolerate such force without distorting.

Following the datum clamping instructions will prevent this magnetic force from disturbing the scale (see 'Fitting the datum clamp' on page 30).

Limit trigger point

The limit output is nominally asserted when the readhead limit switch sensor passes the limit magnet leading edge, but can trigger up to 3 mm before that edge (see 'RTL20-S scale installation drawing' on page 26).

NOTES:

- The reference and limit magnets may creep when influenced by magnetic materials in close proximity. In such cases, they should be held in place using an additional fillet of epoxy glue or similar along the outer edge of the magnet assembly. Optional bolted reference and limit magnets are available (see 'RTL20-S scale installation drawing' on page 26).
- The reference mark selector and limit actuator locations are correct for the readhead orientation shown.
- The reference mark selector magnet is only required for 'Customer selectable reference mark' readheads. For more information refer to *TONiC™ FS encoder system* data sheet (Renishaw part no. L-9517-9878).
- External magnetic fields greater than 6 mT, in the vicinity of the readhead, may cause false activation of the limit and reference sensors.

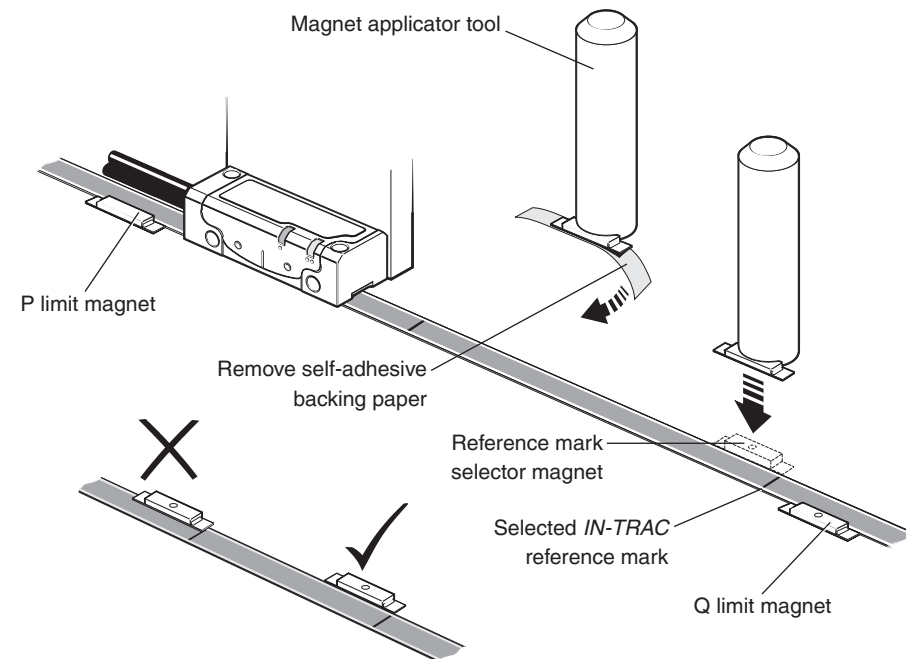

TONiC quick-start guide

This section is a quick-start guide to installing a TONiC FS system. More detailed information on installing the system is contained on page 33 to page 41 of this installation guide.

INSTALLATION

Ensure the scale, readhead optical window and mounting faces are clean and free from obstructions.



If required, ensure reference mark selector magnet is correctly positioned (see 'RTLC20-S scale installation drawing' on page 26).



Plug the readhead cable into the Ti/DOP interface under the cover plate and reassemble the interface (see 'System connection - Ti interface' on page 34 or 'System connection - DOP interface' on page 36). Connect to the receiving electronics and power-up.



Ensure that Automatic Gain Control (AGC) is switched off; the CAL LED on the readhead should be off (if not, press and hold the CAL button on the interface until the CAL LED on the readhead switches off).



Install and align the readhead to maximise signal strength over the full axis of travel as indicated by the readhead and interface set-up LEDs (readhead – green; DOP interface – ideally blue/purple).

CALIBRATION

Press and release the CAL button on the interface.
The CAL LED on the readhead will be single flashing.



Move the readhead at slow speed (< 100 mm/s), without passing a reference mark, until the CAL LED starts double-flashing.



No reference mark

If a reference mark is not being used, the calibration routine should now be exited by pressing and releasing the CAL button. The CAL LED will stop flashing.

Reference mark

Move the readhead back and forth over the reference mark until the CAL LED stops flashing and remains 'off'.



The system is now calibrated and ready for use.

For the safety function to be valid, customer commissioning tests must be performed:
see 'Commissioning test' on page 14.

AGC can now be switched on if required by pressing and holding the CAL button until the CAL LED on the readhead switches on.

Calibration (CAL) values and AGC status are stored in readhead non-volatile memory at power down.

NOTE: If calibration fails, restore factory defaults (see 'Restoring factory defaults' on page 41). Then repeat the installation and calibration routine.

Cable connection

- The cable must be secured to a part that does not move relative to the readhead using a suitable clip within 50 mm of exiting the readhead with a minimum bend radius > 10 mm.
- Cable rolling radius must be > 25 mm when the cable is routed through moving trunking/a cable chain.

NOTE: UHV cables are for static use only.

- The cable must be routed to avoid all moving parts of the machinery and the readhead itself.
- Route the cable away from operating environments that will exceed the EMC limits defined in IEC 61800-5-2: Annex E second environment.
- Use only Renishaw approved cables between the readhead and the interface.
- The customer is responsible for verifying the product function where the cable has been re-terminated, including the installation of extension cables. This includes EMC performance of the installed system defined in IEC 61800-5-2: Annex E second environment.
- The sine and cosine signals must be connected as described in '[Electrical connections](#)' on page 45.

System connection - Ti interface

Approved ESD precautions must be followed at all times during readhead and interface electrical connections.

The readhead is connected to the Ti interface via a small, rugged connector to allow for easy feed-through during installation.

Connecting the readhead

4. Remove the cover plate as shown (2 × M2.5 hex head screws).

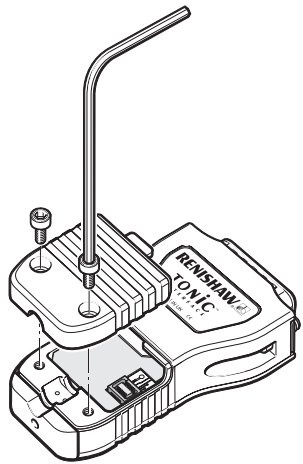

5. Taking care not to touch the pins, plug the connector into the socket in the interface, ensuring correct orientation as shown.

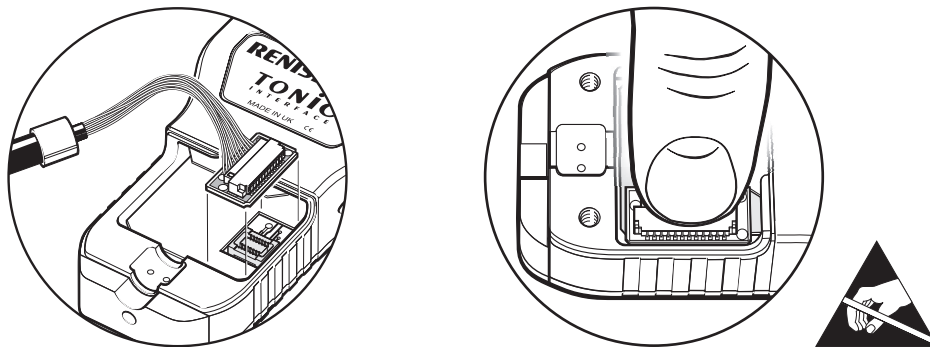

5. Refit the cover plate ensuring the cable ferrule is located in the recess on the inside and no wires are trapped under the cover plate.

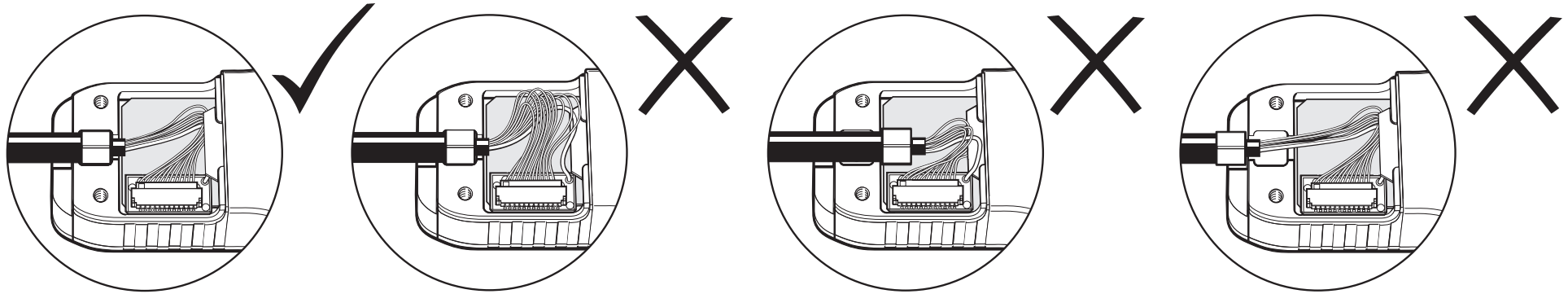

Disconnecting the readhead

1. Remove the cover plate on the interface (2 × M2.5 hex head screws).
2. Gently lever the connector PCB (on the end of the cable) out of the socket. Do not pull the cable to remove the connector.

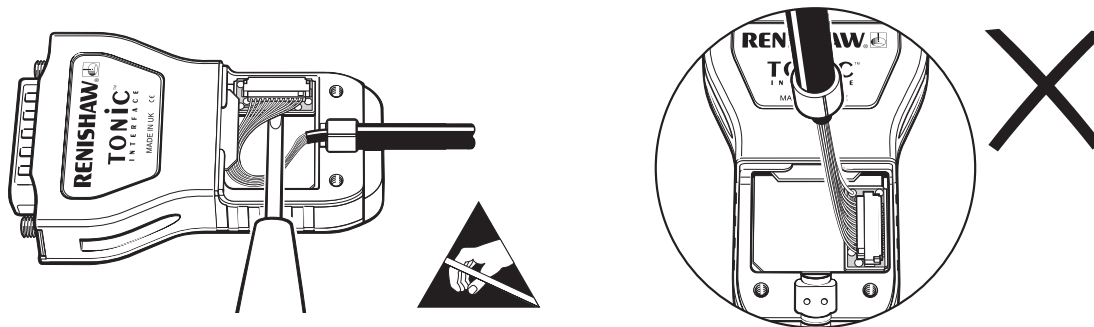

3. Place the connector in an anti-static bag.
4. Refit the cover plate.

System connection - DOP interface

Approved ESD precautions must be followed at all times during readhead and interface electrical connections.

The readhead is connected to the DOP interface via a small, rugged connector to allow for easy feed-through during installation.

Connecting the readhead

1. Remove the cover plate as shown (2 × M2.5 hex head screws).
2. Taking care not to touch the pins, plug the connector into the socket in the interface, ensuring correct orientation as shown.
3. Refit the cover plate ensuring the cable ferrule is located in the recess on the inside and no wires are trapped under the cover plate.

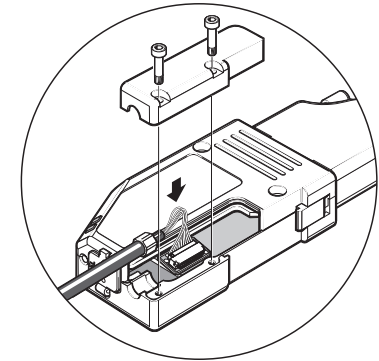

DOP interface mounting

The DOP interface can be DIN rail mounted or mounted to a suitable surface using customer-supplied screws.

NOTES:

- The recommended screw type M3 × 0.5 and must comply with: ISO 4762/DIN 912 grade 8.8 minimum/ANSI B18.3.1M.
- No washer is required under the screw head.
- The minimum thread engagement is 6 mm.
- The tightening torque should be between 0.9 Nm and 1.1 Nm.
- The DIN rail mounting, where used, must comply with EN 50022.

Disconnecting the readhead

1. Remove the cover plate on the interface (2 × M2.5 hex head screws).
2. Gently lever the connector PCB (on the end of the cable) out of the socket. Do not pull the cable to remove the connector.
3. Place the connector in an anti-static bag.
4. Refit the cover plate.

Readhead mounting and alignment

Mounting brackets

The bracket must have a flat mounting surface and should provide adjustment to enable conformance to the installation tolerances, allow adjustment to the rideheight of the readhead, and be sufficiently stiff to prevent deflection or vibration of the readhead during operation.

NOTES:

- The recommended screw type M2.5 × 0.45 and must comply with: ISO 4762/DIN 912 grade 8.8 minimum/ANSI B18.3.1M.
 - The use of a thread locking compound is recommended.
 - No washer is required under the screw head.
 - The minimum thread engagement is 5 mm (7.5 mm including counterbore).
 - The tightening torque should be between 0.25 Nm and 0.4 Nm.
 - The mounting hole clearance will contribute to mechanical safe position.
-

Readhead set-up

Ensure that the scale, readhead optical window and mounting face are clean and free from obstructions.

NOTE: When cleaning the readhead and the scale apply the cleaning fluid sparingly, do not soak.

To set the nominal rideheight, place the green spacer with the aperture under the optical centre of the readhead to allow normal LED function during set-up procedure. Adjust the readhead to maximise the signal strength along the full axis of travel to achieve a green set-up LED on the readhead (> 70% signal). If a DOP interface is used, aim for a blue LED on the interface.

NOTE: The readhead should be installed and set-up with the Automatic Gain Control (AGC) switched off (CAL LED off). When reinstalling the readhead the factory defaults should be restored (see 'Restoring factory defaults' on page 41).

Readhead set-up LED status



NOTE: For full readhead and interface LED diagnostics, see 'Diagnostic LEDs' on page 39.

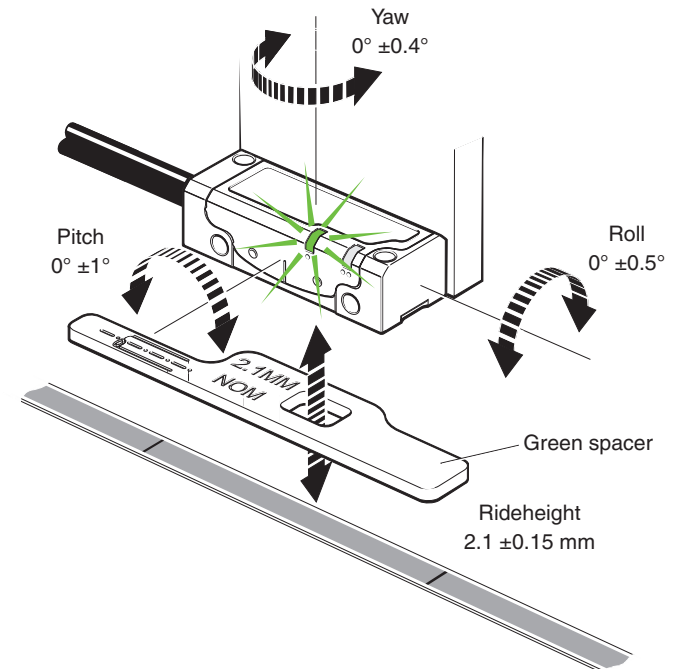

DOP interface set-up LED status

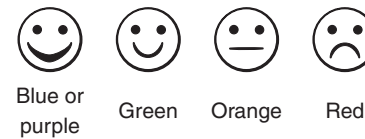

Diagnostic LEDs

T3x3x readhead LEDs

LED		Indication	Status
Set-up	Incremental	Green	Normal set-up: signal level > 70%
		Orange	Signal level 50% to 70% ²
		Red	Signal may be too low for reliable operation; signal level < 50%
	Reference mark	Green (flash) ¹	Normal phasing
		Orange (flash)	Acceptable phasing
		Red (flash)	Poor phasing; clean scale and recalibrate if required
CAL	Operating	On	Automatic Gain Control – On
		Off	Automatic Gain Control – Off
	Calibration	Single-flashing	Calibrating incremental signals
		Double-flashing	Calibrating reference mark
	Reset	Flashing at power-up (< 2s)	Restore factory defaults

DOP interface set-up LED

Signal	Indication	Status	Alarm output
Incremental	Purple	Normal setup; signal level 110% to 135%	No
	Blue	Optimum setup; signal level 90% to 110%	No
	Green	Normal set-up: signal level 70% to 90%	No
	Orange	Signal level 50% to 70% ³	No
	Red	Signal may be too low for reliable operation; signal level < 50%	No
	Red / blank - flashing	Signal level < 20%; system in error	Yes
	Blue / blank - flashing	Overspeed; system in error	Yes
	Purple / blank - flashing	Over signal; system in error	Yes
Reference mark	Blank flash	Reference mark detected (speed < 100 mm/s only)	No

NOTES:

- Alarm output will take the form of 3-state or line driven E signal depending on interface configuration. Also, some configurations do not output overspeed alarm. See *TONiC™ FS encoder system data sheet* (Renishaw part no. L-9517-9878) for details of interface configuration.
- Momentary alarm output status only, while fault condition remains.
- Alarm may result in axis position error, re-datum to continue.

¹ The flash will effectively be invisible when passing the reference mark if the incremental signal is > 70%.

² For Functional Safe applications the set-up LED must be green. See 'Evaluation unit monitoring' on page 14.

³ For Functional Safe applications the LED must be purple, blue or green. See 'Evaluation unit monitoring' on page 14.

System calibration

Calibration is an essential operation that completes readhead set-up, with the optimum incremental and reference mark signal settings stored in the readhead's non-volatile memory.

Before system calibration:

1. Ensure the scale and readhead optical window are clean (contamination around the reference mark may result in reference mark dephasing).
2. If reinstalling, restore factory defaults (see 'Restoring factory defaults' on page 41).
3. Ensure Automatic Gain Control is switched off (CAL LED on readhead is not illuminated) before beginning calibration (see 'Switching Automatic Gain Control (AGC) on or off' on page 41).
4. Ensure signal strength has been optimised along the full axis of travel; the readhead LED will be green.

NOTE: CAL routine maximum speed: < 100 mm/s or less than the readhead maximum speed, whichever is slowest.

Incremental signal calibration

1. Press and release the CAL button on the end of the interface (for < 2 seconds) using a 2 mm allen key or similar tool.

WARNING: Activating the CAL switch only requires 2.5 N force. Applying excess force may permanently damage the switch.

2. The CAL LED will now periodically single-flash to indicate that it is in incremental signal calibration mode.
3. Move the readhead along the axis, ensuring you do not pass the reference mark until the CAL LED starts double-flashing. This indicates the incremental signal is now calibrated and the new settings are stored in the readhead memory.
4. The system is now ready for reference mark phasing.
5. For systems without a reference mark, go to 'Calibration routine – manual exit' on page 41.
6. If the system does not automatically enter the reference mark phasing stage (no double-flashing of the CAL LED) the calibration of the incremental signals has failed. After ensuring failure is not due to overspeed, exit the calibration routine, restore factory defaults (see 'Restoring factory defaults' on page 41) and check the readhead installation and system cleanliness before repeating the calibration routine.

Ti interface

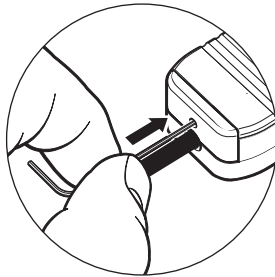

DOP interface

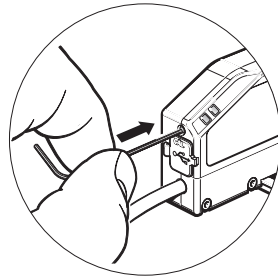

Reference mark phasing

1. Move the readhead back and forth over the selected reference mark until the CAL LED stops flashing and remains off. The reference mark is now phased.
2. The system automatically exits the CAL routine and is ready for operation.
3. For the safety function to be valid, customer commissioning tests must be performed: see '[Commissioning test](#)' on page 14.
4. If the CAL LED continues double-flashing after passing the chosen reference mark many times, it is not detecting the reference mark. Ensure that the correct readhead configuration is being used. Readheads can either output all reference marks or only output a reference mark where a reference selector magnet is fitted depending on the options chosen when ordering.

NOTE: The LED on the interface will flash blank when the reference mark is detected (> 100 mm/s only). It indicates the presence of a reference mark, not the phasing status.

Calibration routine – manual exit

1. To exit the calibration routine at any stage press the CAL button. The CAL LED will stop flashing.
2. For the safety function to be valid, customer commissioning tests must be performed: see '[Commissioning test](#)' on page 14.

CAL LED status during system calibration

CAL LED	Settings stored
Single flashing	None, restore factory defaults and recalibrate
Double flashing	Incremental only
Off (auto-complete)	Incremental and reference mark

Restoring factory defaults

When realigning the readhead, reinstalling the system, or in the case of continued calibration failure, factory defaults must be restored.

To restore factory defaults:

1. Switch system off.
2. Press and hold the CAL button whilst switching the system on. The CAL LED on the readhead will flash several times, indicating that the factory defaults have been restored.
3. Release the CAL button.
4. Check the '[Readhead mounting and alignment](#)' on page 37 and recalibrate the system (see '[System calibration](#)' on page 40).

NOTE: System must be recalibrated after restoring factory defaults.

Switching Automatic Gain Control (AGC) on or off

The AGC can be switched on or off via the interface.

Press and hold the CAL button on the interface for > 3 seconds to switch AGC on or off. The CAL LED on the readhead will be illuminated when AGC is active.

NOTE: The system must be calibrated before switching AGC on (see '[System calibration](#)' on page 41).

Output signals

NOTE: Only analogue sine and cosine outputs are functionally safe.

Readhead output

Function	Output type		Signal		Colour
Power	-		5 V Power		Brown
			0 V Power		White
Incremental signals	Analogue	Cosine	V_1	+	Red
				-	Blue
		Sine	V_2	+	Yellow
				-	Green
Reference mark	Analogue		V_0	+	Violet
				-	Grey
Limits	Open collector		V_p		Pink
			V_q		Black
Set-up	-		V_x		Clear
Calibrate	-		CAL		Orange
Shield	-		Inner shield ¹		Green/Yellow
	-		Outer shield		Outer screen

Ti0000 interface output

Function	Output type		Signal		Pin
Power	-		5 V Power		4
			5 V Sense		5
			0 V Power		12
			0 V Sense		13
Incremental signals	Analogue	Cosine	V_1	+	9
				-	1
		Sine	V_2	+	10
				-	2
Reference mark	Analogue		V_0	+	3
				-	11
Limits	Open collector		V_p		7
			V_q		8
Set-up	-		V_x		6
Calibrate	-		CAL		14
Shield	-		Inner shield		Not connected
	-		Outer shield		Case



Ti0000 interface output connector: 15-way D-type plug

¹ There is no inner shield on UHV cables.

DOP interface output

Function	Output type	Signal	Pin		
Power	-	5 V Power	26		
		5 V Sense	18		
		0 V Power	9		
		0 V Sense	8		
Incremental signals	RS422A digital	A	+	24	
			-	6	
		B	+	7	
			-	16	
	Analogue	Cosine	V ₁	+	1
				-	19
Sine	V ₂	+	2		
		-	11		
Reference mark	RS422A digital	Z	+	15	
			-	23	
	Analogue	V ₀	+	12	
			-	20	
Alarm	RS422A digital	E	+	25	
			-	17	
Limits	Open collector	P	4		
		Q	13		
Readhead set-up	-	X	10		
Shield	-	Inner shield	Not connected		
	-	Outer shield	Case		

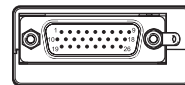

DOP interface output
connector: 26-way
high-density D-type plug

Speed

Clocked output option (MHz)	Maximum speed (m/s)										
	DOP0004 5 µm	DOP0020 1 µm	DOP0040 0.5 µm	DOP0100 0.2 µm	DOP0200 0.1 µm	DOP0400 50 nm	DOP1000 20 nm	DOP2000 10 nm	DOP4000 5 nm	DOP10KD 2 nm	DOP20KD 1 nm
50	10	10	10	6.48	3.24	1.62	0.648	0.324	0.162	0.0654	0.032
40	10	10	10	5.40	2.70	1.35	0.540	0.270	0.135	0.054	0.027
25	10	10	8.10	3.24	1.62	0.810	0.324	0.162	0.081	0.032	0.016
20	10	10	6.75	2.70	1.35	0.675	0.270	0.135	0.068	0.027	0.013
12	10	9	4.50	1.80	0.900	0.450	0.180	0.090	0.045	0.018	0.009
10	10	8.10	4.05	1.62	0.810	0.405	0.162	0.081	0.041	0.016	0.0081
08	10	6.48	3.24	1.29	0.648	0.324	0.130	0.065	0.032	0.013	0.0065
06	10	4.50	2.25	0.90	0.450	0.225	0.090	0.045	0.023	0.009	0.0045
04	10	3.37	1.68	0.67	0.338	0.169	0.068	0.034	0.017	0.0068	0.0034
01	4.2	0.84	0.42	0.16	0.084	0.042	0.017	0.008	0.004	0.0017	0.0008
Analogue output (Ti0000 and DOP)	10 (-3dB)										

Electrical connections

Grounding and shielding - standard TONiC system

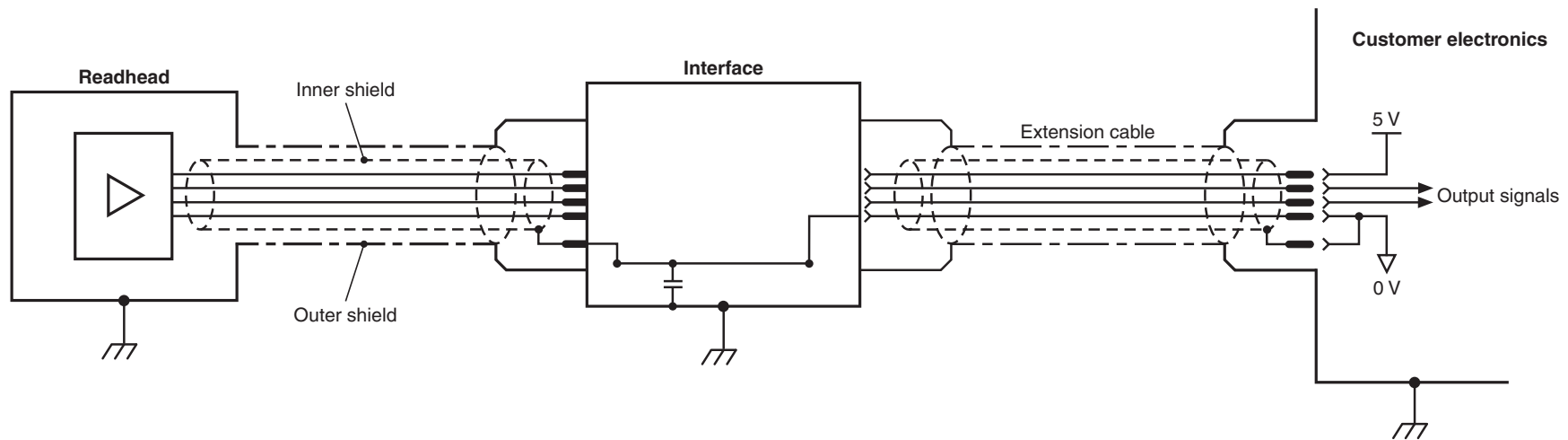

IMPORTANT: The outer shield should be connected to the machine earth (Field Ground). The inner shield should be connected to 0 V at the receiving electronics only. Care should be taken to ensure that the inner and outer shields are insulated from each other. If the inner and outer shields are connected together, this will cause a short between 0 V and earth, which could cause electrical noise issues.

NOTES:

- The maximum cable length between the readhead and the interface is 10 m
- The maximum extension cable is dependent on the cable type, the readhead cable length and the clock speed. Contact your local Renishaw representative for more information.
- For DOP interfaces the external earthing tag on the interface must be used when mounting the interface on a DIN rail.

Grounding and shielding - Ultra-high vacuum (UHV) TONiC system

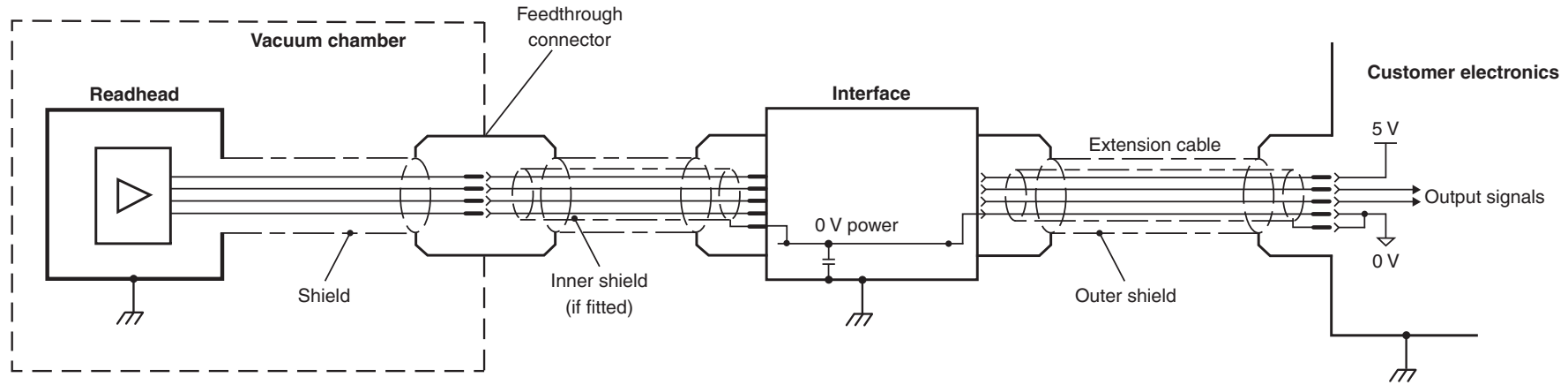

IMPORTANT: The outer shield should be connected to the machine earth (Field Ground). The inner shield should be connected to 0 V at receiving electronics only. Care should be taken to ensure that the inner and outer shields are insulated from each other. If the inner and outer shields are connected together, this will cause a short between 0 V and earth, which could cause electrical noise issues.

NOTES:

- The maximum cable length between the readhead and the interface is 10 m
- The maximum extension cable is dependent on the cable type, the readhead cable length and the clock speed. Contact your local Renishaw representative for more information.
- For DOP interfaces the external earthing tag on the interface must be used when mounting the interface on a DIN rail.

Recommended signal termination ¹

Analogue outputs

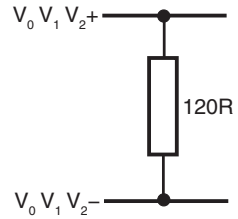

Limit outputs

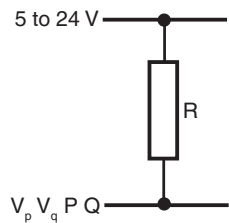

NOTE: Select the resistor R so that the maximum current does not exceed 20 mA.
Alternatively use a suitable relay or opto-isolator.

Digital outputs (DOP only)

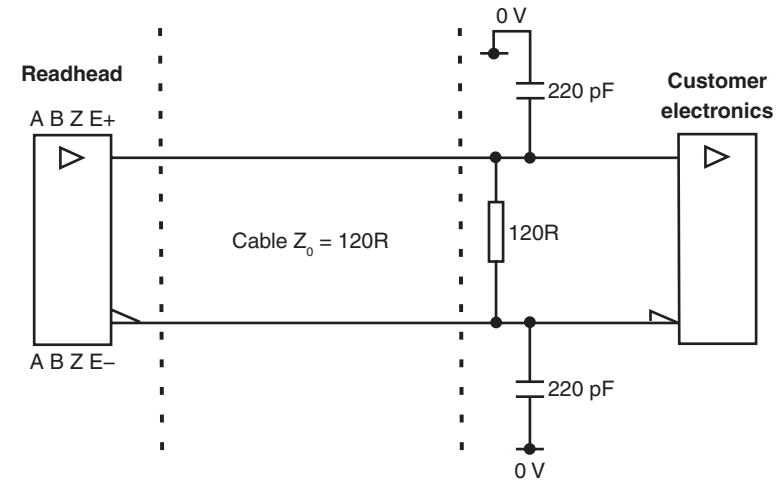

Standard RS422A line receiver circuitry.

The capacitors are recommended for improved noise immunity.

Remote CAL operation

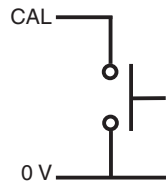

Ti and DOP interfaces include a push-button switch to enable CAL/AGC features.
However, remote operation of the CAL/AGC is possible via pin 14 of analogue Ti0000 interfaces.

¹ Only the analogue sine and cosine outputs are functionally safe.

Ti interface output specifications

Analogue signals ¹

Incremental

2 channels V_1 and V_2 differential sinusoids in quadrature centred on ~ 1.65 V (90° phase shifted)

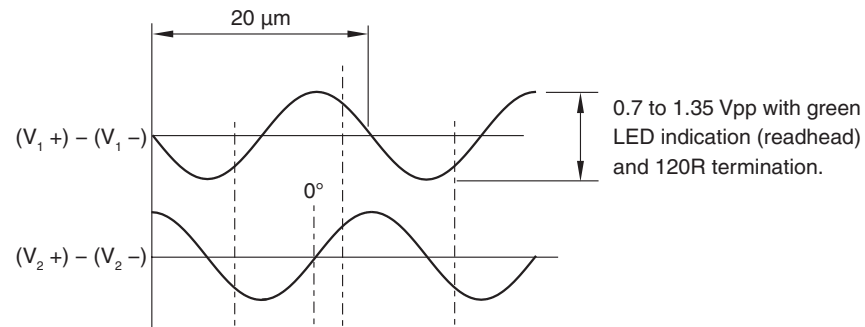

Reference

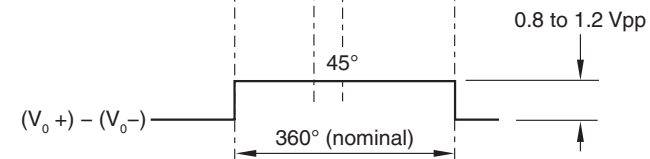

The reference output is bi-directionally repeatable.

The differential pulse V_o is centred on 45° .

¹ Only the analogue sine and cosine outputs are functionally safe.

Limits

Open collector output, asynchronous pulse

Ti0000 interfaces (active high)

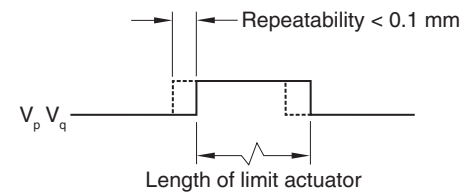

T3x3x readheads (active low)

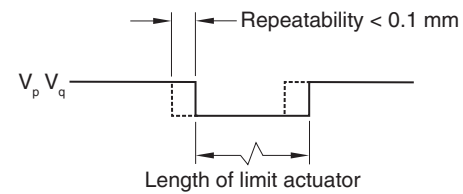

Ti interface set-up ¹

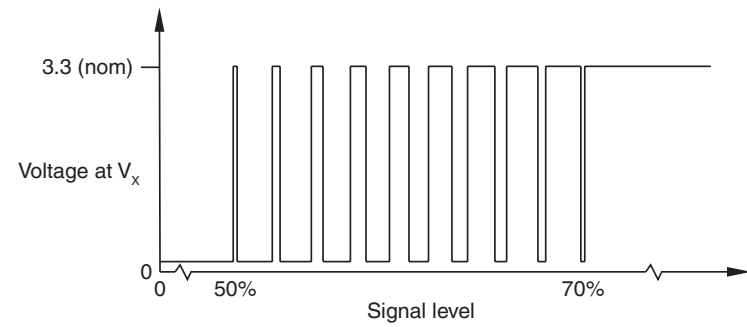

Between 50% and 70% the signal level V_x is a duty cycle.

Time spent at 3.3 V increases with incremental signal level.

At > 70% the signal level V_x is nominal 3.3 V.

¹ The set-up signal as shown is not present during the calibration routine.

DOP interface output specifications

Analogue signals ¹

Incremental

2 channels V_1 and V_2 differential sinusoids in quadrature centred on 2.5 V (90° phase shifted)

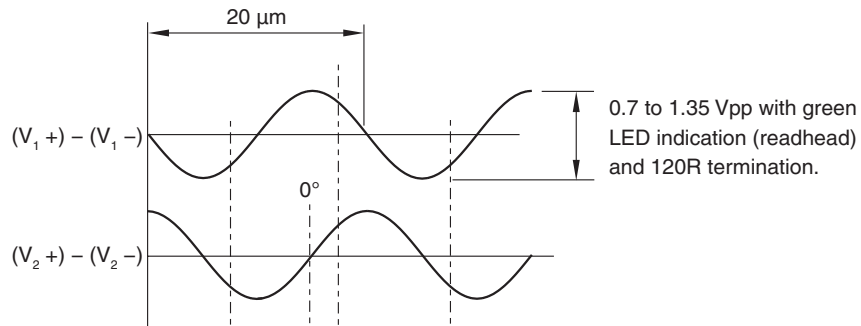

Reference

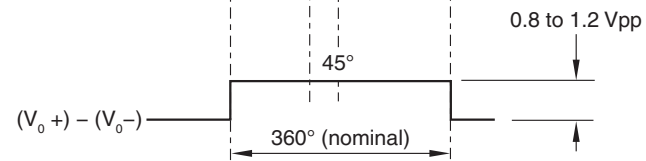

The reference output is bi-directionally repeatable.

The differential pulse V_0 is centred on 45°.

¹ Only the analogue sine and cosine outputs are functionally safe.

² For clarity, the inverse signals are not shown.

Digital signals ¹

Form – Square wave differential line driver to EIA RS422A (except limits P and Q)

Incremental ²

2 channels A and B in quadrature (90° phase shifted)

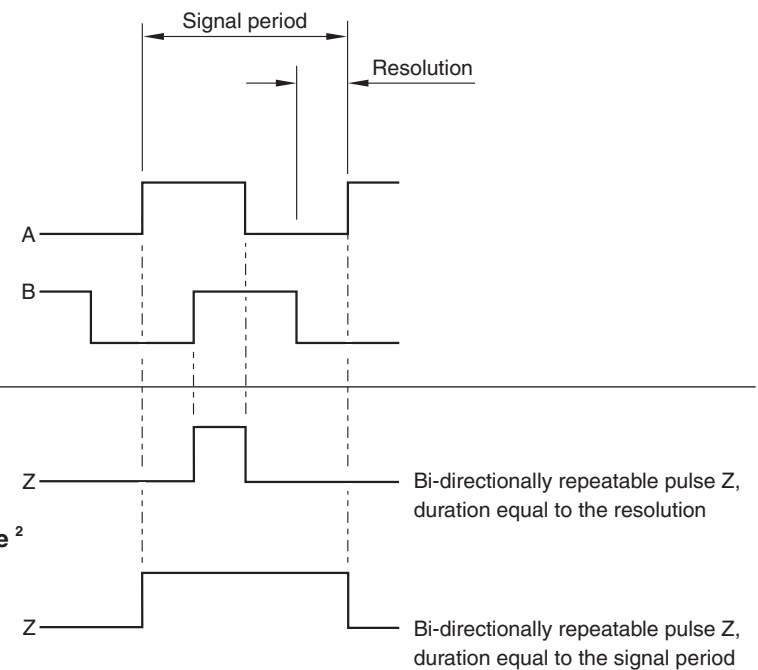

NOTE: Select 'standard' or 'wide' reference at time of ordering, to match the requirements of the controller being used.

Limits

Open collector output, asynchronous pulse

Active high

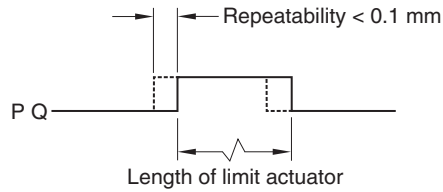

or active low

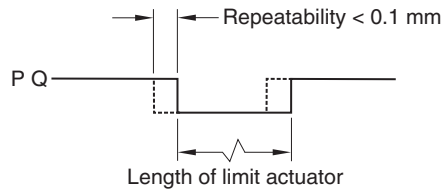

Alarm

Line driven¹ (asynchronous pulse)

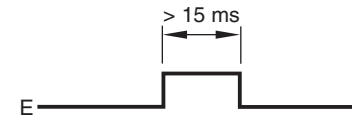

The line driven alarm is asserted when:

- The signal amplitude is < 20% or > 135%
- The readhead speed is too high for reliable operation

or 3-state alarm

Differentially transmitted signals are forced open circuit for > 15 ms when the alarm conditions are valid.

DOP set-up²

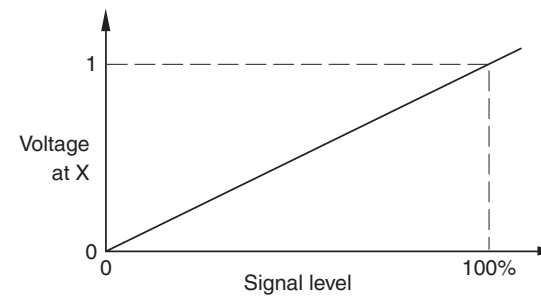

The set-up signal voltage is proportional to the incremental signal amplitude.

¹ For clarity, the inverse signals are not shown.

² The set-up signal as shown is not present during the calibration routine.

General specifications

Power supply	5 V \pm 10% Ripple	Readhead only < 100 mA T3x3x with Ti0000 < 100 mA T3x3x with DOP < 275 mA Current consumption figures refer to unterminated systems. For digital outputs a further 25 mA per channel pair (eg A+, A-) will be drawn when terminated with 120R. For analogue outputs a further 20 mA in total will be drawn when terminated with 120R. Power from a 5 V dc supply complying with the requirements for PELV of standard IEC 60950-1. 200 mVpp maximum @ frequency up to 500 kHz
Temperature	Storage (system) Operating (system) Bakeout (UHV readhead)	-20 °C to +70 °C 0 °C to +70 °C +120 °C
Humidity	System	95% relative humidity (non-condensing) to IEC 60068-2-78
Sealing	Standard readhead UHV readhead Ti interface DOP interface	IP40 IP20 IP20 IP30
Acceleration	Operating (readhead)	500 m/s ² , 3 axes
Shock	Operating (system)	500 m/s ² , 11 ms, ½ sine, 3 axes
Vibration	Operating (system)	100 m/s ² , 55 Hz to 2000 Hz, 3 axes
Mass	Readhead Ti interface DOP interface Standard cable UHV cable	10 g 100 g 205 g 26 g/m 14 g/m
Readhead cable	Standard readhead UHV readhead	Double-shielded, outside diameter 4.25 \pm 0.25 mm Flex life > 20 \times 10 ⁶ cycles at 20 mm bend radius UL recognised component  Tin coated braided single screen FEP core insulation
Maximum cable length	Readhead to interface Interface to controller	10 m 25 m (with 40 MHz to 50 MHz clocked output interface) 50 m (with < 40 MHz clocked output interface) 50 m (with analogue interface)

CAUTION: Renishaw encoder systems have been designed to the relevant EMC standards, but must be correctly integrated to achieve EMC compliance. In particular, attention to the shielding arrangements is essential. For UHV cables ensure that the cable to UHV connector termination meets the EM requirements defined by IEC 61800-5-2: Annex E second environment.

RTL20-S scale specifications

Form (height x width)	0.4 mm x 8 mm (including adhesive)
Pitch	20 µm
Accuracy (at 20 °C) - includes slope and linearity	±5 µm/m (calibration traceable to International Standards)
Linearity	±2.5 µm/m (achievable with two point error correction)
Supplied lengths ¹	20 mm up to 5 m
Material	Hardened and tempered martensitic stainless steel fitted with a self-adhesive backing tape
Mass	12.9 g/m
Coefficient of thermal expansion (at 20 °C)	10.1 ±0.2 µm/m/°C
Installation temperature	+10 °C to + 35 °C
Thermal expansion mismatch	$(CTE_{\text{substrate}} - CTE_{\text{scale}}) \times \Delta T \times L$ Where ΔT is the temperature range between installation and the extreme of operating or storage and L is the scale length between the datum and its furthest end.
Datum fixing	Loctite® 435™ with A-9585-0028 datum clamp

¹ For lengths > 2 m *FASTRACK* with RTL20 is recommended. Refer to the *TONIC™ FS T3x3x RTL20 and FASTRACK linear encoder system Functional Safety installation guide and safety manual* (Renishaw part no. M-6688-9047).

Reference mark



Type	Customer selected <i>IN-TRAC</i> reference mark, directly embedded into incremental track. Bi-directional position repeatability.
Selection	Single reference mark selection by selector magnet (A-9653-0143) customer positioned
L ≤ 100 mm	Single reference mark at scale centre
L > 100 mm	Reference marks at 50 mm spacing (first reference mark 50 mm from scale end)
Mounting	Self-adhesive backing tape or bolted
Repeatability	Unit of resolution repeatability (bi-directional) across full system rated speed and temperature ranges

Limit switches

Type	Magnetic actuators; with dimple triggers Q limit, without dimple triggers P limit (see ' RTL20-S scale installation drawing ' on page 26)
Trigger point	The limit output is nominally asserted when the readhead limit switch sensor passes the limit magnet leading edge, but can trigger up to 3 mm before that edge
Mounting	Self-adhesive backing tape or bolted. Customer placed at desired locations
Repeatability	< 0.1 mm

www.renishaw.com/contact

 #renishaw

 **+44 (0) 1453 524524**  **uk@renishaw.com**

© 2019–2023 Renishaw plc. All rights reserved. This document may not be copied or reproduced in whole or in part, or transferred to any other media or language by any means, without the prior written permission of Renishaw.
RENISHAW® and the probe symbol are registered trade marks of Renishaw plc. Renishaw product names, designations and the mark 'apply innovation' are trade marks of Renishaw plc or its subsidiaries.
Other brand, product or company names are trade marks of their respective owners.
Renishaw plc. Registered in England and Wales. Company no: 1106260. Registered office: New Mills, Wotton-under-Edge, Glos, GL12 8JR, UK.

WHILE CONSIDERABLE EFFORT WAS MADE TO VERIFY THE ACCURACY OF THIS DOCUMENT AT PUBLICATION, ALL WARRANTIES, CONDITIONS, REPRESENTATIONS AND LIABILITY, HOWSOEVER ARISING, ARE EXCLUDED TO THE EXTENT PERMITTED BY LAW. RENISHAW RESERVES THE RIGHT TO MAKE CHANGES TO THIS DOCUMENT AND TO THE EQUIPMENT, AND/OR SOFTWARE AND THE SPECIFICATION DESCRIBED HEREIN WITHOUT OBLIGATION TO PROVIDE NOTICE OF SUCH CHANGES.

Part no.: M-6688-9044-03-A
Issued: 04.2023